



Enhancing our communities





Victoria Annex

STORMWATER MANAGEMENT REPORT

Georgian Communities

Document Control

File:	Prepared by:	Prepared for:
120174	Tatham Engineering Limited 115 Sandford Fleming Drive, Suite 200 Collingwood, Ontario L9Y 5A6 T 705-444-2565 tathameng.com	Georgian Communities 85 Bayfield Street, Suite 500 Barrie, Ontario L4M 3A7
Date:		
October 21, 2021		

Authored by:	Reviewed by:
	
Kevin Sansom, B.A.Sc., P.Eng. Senior Engineer	

Disclaimer	Copyright
The information contained in this document is solely for the use of the Client identified on the cover sheet for the purpose for which it has been prepared and Tatham Engineering Limited undertakes no duty to or accepts any responsibility to any third party who may rely upon this document.	This document may not be used for any purpose other than that provided in the contract between the Owner/Client and the Engineer nor may any section or element of this document be removed, reproduced, electronically stored or transmitted in any form without the express written consent of Tatham Engineering Limited.

Issue	Date	Description
1	November 19, 2020	Final Report
2	April 7, 2021	Revision 1
3	October 21, 2021	Revision 2

Document Contents

- 1 Introduction 1**
- 2 Development Site 2**
 - 2.1 Site Location 2
 - 2.2 Existing Conditions 2
 - 2.3 Proposed Development 3
- 3 Pre-Development Drainage Conditions 4**
 - 3.1 Existing Drainage System 4
 - 3.2 Runoff Coefficients 5
 - 3.3 Peak Flows 5
- 4 Post-Development Drainage Conditions 7**
 - 4.1 Proposed Drainage System 7
 - 4.2 Runoff Coefficients 8
 - 4.3 Peak Flows 9
 - 4.4 Stormwater Quality 11
- 5 Siltation & Erosion Control 13**
- 6 Summary 14**

Tables

- Table 1: Pre-Development Composite Runoff Coefficients 5
- Table 2: Pre-Development Runoff Rates by Catchment 5
- Table 3: Pre-Development Runoff Rates by Outlet 6
- Table 4: Post-Development Composite Runoff Coefficients 8
- Table 5: Post-Development Runoff Rates by Catchment 9
- Table 6: Post-Development Runoff Rates by Outlet 10
- Table 7: Storage Volume & Orifice Discharge for Sixth Street 11



Drawings

Figure 1: Site Location Map

SP-1: Site Plan

DP-1: Pre-Development Drainage Plan

DP-2: Post Development Drainage Plan

STM-1: Storm Sewer Design Plan

SG-1: Site Grading Plan

EC-1: Siltation and Erosion Control Plan

Appendices

Appendix A: Pre-Development Runoff Calculations

Appendix B: Post-Development Runoff Calculations

Appendix C: Modified Rational Method for Quantity Control Storage Requirements

Appendix D: Orifice Discharge Calculations

Appendix E: Stormceptor Sizing



1 Introduction

Tatham Engineering Limited has been retained by Georgian Communities to prepare a Stormwater Management Report in support of the Victoria Annex Residential Development in the Town of Collingwood. This Stormwater Management (SWM) report provides a summary of existing and proposed drainage conditions for the subject property and confirms the stormwater management design meets current standards and guidelines and best efforts as they relate to existing conditions and constraints. Mitigative strategies for siltation and erosion control for the development will also be addressed.

This report was prepared recognizing provincial and municipal guidelines on water resources and the environment, including the following publications:

- The Ministry of Environment, Conservation and Parks (MECP) *Stormwater Management Planning and Design Manual (March 2003)*
- The Nottawasaga Valley Conservation Authority (NVCA) *Stormwater Technical Guide (December 2013)*
- The Nottawasaga Valley Conservation Authority (NVCA) *Technical Design Guidelines, Standard, and Policies for Siltation and Erosion Control (July 2003)*
- The Ministry of Transportation Ontario (MTO) *Drainage Manual (1994)*
- *Town of Collingwood Development Standards (July 2007)*



2 Development Site

2.1 SITE LOCATION

The subject site is located at 400 Maple Street in the Town of Collingwood and is bounded by Fifth Street to the north, Sixth Street to the south, Maple Street to the east and existing residential properties to the west. The legal description of the property is (Part 1) Lots 10, 11 and 12 on Registered Plan 45 located in the Town of Collingwood, County of Simcoe.

A site location map has been provided as Figure 1.

2.2 EXISTING CONDITIONS

2.2.1 Development Site

The subject site houses the former Victoria Public School, which has been vacant since 2001, and has a total site area of approximately 0.60 ha. The abandoned school building is located in the middle of the site along the west property line and is approximately 235 m² in size. There are gravel areas located to the north and south of the building, and both are approximately 2,320 m² in size. There is also a grass area located east of the school with a size of approximately 1,065 m² in size. The entire site is surrounded by a chain link fence. A topographic survey for the site and adjacent streets was completed by Tatham in June 2005.

2.2.2 Subsurface Conditions

Terraprobe Inc. completed test pits for the property in January 2005 and May 2015. Soils found were fine sand and grey silt ranging in depths of 1.2 to 2.0 metres respectively. Heavy clay and shale were discovered below depths of 2.5 metres and bedrock elevations were expected to be encountered at approximately 3 metres. However, ground water elevations, which were approximately 1.5 metres below grade, caused the test pits to collapse. Brick debris, concrete blocks and fill from a previously demolished school building was also found within the property.

Terraprobe completed an additional investigation in October 2020, which included 9 boreholes and groundwater monitoring. Results from this investigation were similar to the previous findings namely:

- 6 boreholes were comprised of sand at depths ranging from 0.05 to 2.6 metres;
- 3 boreholes were comprised of fill at depths ranging from 0.05 to 2.3 metres;
- all boreholes contained sandy silt below the sand or fill layers at depths of 2.3 to 4.7 metres;



- auger refusal was encountered between 1.6 to 4.7 metres indicating presence of boulders, bedrock or debris;
- groundwater elevations were determined to be a minimum of 1.2 metres below the surface while some boreholes were dry at auger refusal; and
- groundwater elevations are established at approximately ± 184.00 while bedrock elevations are estimated between 180.30 and 182.50.

2.3 PROPOSED DEVELOPMENT

The proposed development will consist of a total of 19 residential units as follows:

- 4 detached residential units fronting the surrounding streets (1 to Fifth Street, 2 to Maple Street and 1 to Sixth Street);
- 10 semi-detached residential units fronting the surrounding streets (2 to Fifth Street, 6 to Maple Street and 2 to Sixth Street);
- 5 condominium units.

Of the 4 detached units, 2 will have detached garages and 2 will have attached garages. The building and garage areas will be approximately 130 m² and 40 m² respectively in size. All of the semi-detached units will have attached garages. The combined building and garage area of these units is approximately 160 m². As noted, all of the detached and semi-detached units will front directly onto the boundary roads.

The existing 235 m² two-storey school building will be converted into 2 dwelling units, accompanied by a 72 m² detached garage immediately adjacent to the east. A second 165 m² condominium building, referred to as the Coach House, will be constructed southeast of the Annex and will contain surface level parking for the 3 dwelling units above. Each of the dwelling units in the Coach House will be approximately 69 m² in size each.

The development will be serviced with municipal water and sanitary sewer connections as well as hydro, gas, cable and telephone.

A preliminary site plan is provided in Drawing SP-1.



3 Pre-Development Drainage Conditions

The pre-development drainage conditions are shown on the Pre-Development Drainage Plan, Drawing DP-1.

3.1 EXISTING DRAINAGE SYSTEM

Currently, the on-site grading divides the minor stormwater runoff events towards 3 drainage areas as detailed below.

- Drainage Area E1 (0.12 ha) is located in the northwest corner of the property and has a runoff coefficient of 0.39.
- Drainage Area E2 (0.17 ha) is located in the northeast corner of the property and has a runoff coefficient of 0.51.
- Drainage Area E3 encompasses the south half of the property and has a runoff coefficient of 0.44.

The three drainage areas discharge into 2 different outlets as follows.

Outlet 1 collects runoff from Drainage Areas E1 and E2 in 2 catch basins which are connected directly to an existing sanitary maintenance hole located in the middle of the property adjacent to the eastern property line. While the pipe network suggests this outlet discharges to the sanitary sewer on Maple Street, the existing catch basins are in poor condition and are blocked with sediment and debris. Furthermore, the catch basins are connected by 100 millimetre diameter pipes to the sanitary maintenance hole and are undersized relative to the size of the catchment areas and thus do not properly convey stormwater. This has been observed in previous storm events whereby the downstream sanitary maintenance hole had no flow passing through from the storm sewer connection. Therefore, in minor and major storm events, ponding occurs in Drainage Areas E1 and E2 and stormwater spills onto Fifth Street. As such, Outlet 1 is considered to outlet to Fifth Street. Outlet 2 collects runoff from Drainage Area E3 via a catch basin which is connected to an existing storm sewer on Sixth Street. The Sixth Street storm sewer discharges westerly to the Oak Street storm drain.



3.2 RUNOFF COEFFICIENTS

The composition of each pre-development drainage area and the associated composite runoff coefficients are shown in Table 1. Runoff coefficients were determined based on the MTO Drainage Manual.

Table 1: Pre-Development Composite Runoff Coefficients

AREA	SIZE (HA)	GRASSED AREA (HA) C = 0.25	GRAVEL AREA (HA) C = 0.80	IMPERVIOUS AREA (HA) C = 0.90	COMPOSITE RUNOFF COEFFICIENT
E1	0.12	0.091	0.007	0.020	0.39
E2	0.17	0.088	0.078	0.001	0.51
E3	0.31	0.211	0.085	0.019	0.44

3.3 PEAK FLOWS

The pre-development peak flow rates were calculated using the Rational Method; calculations are included in Appendix A with the results summarized in Table 2 by catchment area and Table 3 by outlet. It is noted that the blockage of sewers and infiltration of the stormwater runoff into the subgrade was not considered when computing the pre-development runoff rates.

Table 2: Pre-Development Runoff Rates by Catchment

AREA	PRE-DEVELOPMENT PEAK FLOWS (m ³ /s)					
	2 Year	5 Year	10 Year	25 Year	50 Year	100 Year
E1	0.010	0.013	0.015	0.020	0.024	0.027
E2	0.018	0.024	0.028	0.036	0.043	0.050
E3	0.030	0.039	0.045	0.058	0.070	0.081
Total	0.058	0.076	0.088	0.114	0.137	0.158



Table 3: Pre-Development Runoff Rates by Outlet

OUTLET	PRE-DEVELOPMENT PEAK FLOWS (m ³ /s)					
	2 Year	5 Year	10 Year	25 Year	50 Year	100 Year
Maple Street	0.000	0.000	0.000	0.000	0.000	0.000
Fifth Street	0.028	0.037	0.043	0.056	0.067	0.077
Sixth Street	0.030	0.039	0.045	0.058	0.070	0.081
Total	0.058	0.076	0.088	0.114	0.137	0.158

Runoff from the property during major storms currently spill onto and are conveyed along the respective streets adjacent to the property which ultimately outlet to Georgian Bay. Fifth Street and Maple Street are approximately 7 metre wide paved residential roads without curb and gutter. Catch basins are located at the intersection of Fifth Street and Maple Street; however, grading along Fifth Street and Maple Street is relatively flat and runoff collects in low-lying areas along the boulevards. Sixth Street is a 9 metre wide paved collector road consisting of curb and gutter and storm sewer.

The pre-development peak flows summarized in Table 3 form the basis for the post-development stormwater management design, whereby post-development flows will be less than or equal to pre-development flows.



4 Post-Development Drainage Conditions

The post-development drainage conditions are shown on the Post-Development Drainage Plan and the Storm Sewer Design Plan, Drawings DP-2 and STM-1.

4.1 PROPOSED DRAINAGE SYSTEM

As described in the preceding chapter, the north half of the property currently outlets overland directly to Fifth Street while the remaining south half is connected to the existing storm sewer on Sixth Street. Given the site constraints and available outlets, the proposed drainage design re-directs stormwater runoff as follows:

- A large portion of Drainage Area P3 (minor areas 201-205, 0.22 ha total) will be collected in a series of catch basins connected to the existing storm sewer on Sixth Street.
- The remaining portion of Drainage Area P3 (minor areas 101-102, 0.06 ha total) will be collected in a series of catch basins connected to the existing storm sewer on Fifth Street.
- The perimeter Drainage Areas P1, P2 and P4 consist of roofs and driveways and will drain overland as sheet flow across the yards/sidewalks/boulevards and discharge onto the respective streets, similar to the adjacent freehold residential properties in the immediate area.

The proposed internal storm sewer system conveying Drainage Area P3 will be connected to the adjacent streets via 3.0 metre wide easements between units 2B and 3 to Fifth Street and between units 7 and 8A to Sixth Street. The internal storm sewers will be encased in concrete due to the shallow depths (between 0.15 to 0.90 metres deep) and vicinity to the proposed buildings. Inline backflow preventers have been placed immediately downstream of two rear yard catch basins, CB301 and CB404 to prevent flooding of adjacent existing residential properties in the event of a storm sewer surcharge.

Drainage Areas P1 and P2 will drain overland as sheet flow onto Fifth Street and Maple Street, respectively. Runoff along Fifth Street will continue to drain west towards Beech Street while runoff along Maple Street will continue to drain north to the existing storm sewer system at the intersection of Fifth Street and Maple Street. The sidewalks and boulevards along Fifth Street and Maple Street will be raised to provide positive drainage away from the proposed buildings to their respective streets. Concrete curb and gutter will be installed along the development side of Maple Street to improve overland flow. The existing asphalt gutter on Fifth Street will be maintained to convey flows to the storm sewer system.



Similar to Drainage Areas P1 and P2, Drainage Area P4 will drain overland as sheet flow across the existing sidewalk and boulevard along Sixth Street similar to the adjacent residential properties surrounding the development. Runoff along Sixth Street will drain west towards the Oak Street storm drain.

Fill will be placed at moderate depths between 0.0 and 0.5 metres to provide adequate drainage throughout the site. Due to the shallow Seasonal High Ground Water Elevations (SHGWE), the proposed dwelling units have been designed such that the necessary 0.5 metre separation between the SHGWE and the underside of the basement slab is realized. The proposed Coach House will be a slab-on-grade design. Existing contours and proposed drainage patterns are shown on Drawing SG-1.

4.2 RUNOFF COEFFICIENTS

Drainage Area P1 (0.12 ha) is located in the northwest corner of the property fronting Fifth Street, Drainage Area P2 (0.10 ha) is located in the northeast corner of the property fronting Maple Street, Drainage Area P3 (0.28 ha) is located in the middle of the property and Drainage Area P4 (0.11 ha) is located along the southern property line fronting Sixth Street. Drainage Area P3 is subdivided into minor catchment areas based on the internal storm sewer system and includes Internal Drainage Areas 101-102 and 201-205. The composition for each post-development drainage area and composite runoff coefficients are summarized in Table 4.

Table 4: Post-Development Composite Runoff Coefficients

AREA	SIZE (HA)	GRASSED AREA (HA) C = 0.25	IMPERVIOUS AREA (HA) C = 0.90	COMPOSITE RUNOFF COEFFICIENT
P1	0.12	0.043	0.073	0.66
P2	0.10	0.039	0.057	0.64
P3	0.28	0.120	0.159	0.62
101	0.04	0.026	0.015	0.49
102	0.02	0.013	0.006	0.46
201	0.03	0.008	0.018	0.70
202	0.02	0.006	0.019	0.74
203	0.08	0.007	0.075	0.84



204	0.04	0.029	0.015	0.47
205	0.04	0.024	0.018	0.53
P4	0.11	0.047	0.063	0.62

4.3 PEAK FLOWS

The post-development peak runoff rates were calculated using the Rational Method and are included in Appendix B. A summary of the results are presented in Table 5 by drainage area and Table 6 by outlet. Recall Drainage Area P3 is subdivided into Internal Drainage Areas 101-102 which outlet to Fifth Street and 201-205 which outlet to Sixth Street. Note the runoff rates presented in Table 5 and Table 6 represent the uncontrolled condition.

Table 5: Post-Development Runoff Rates by Catchment

AREA LABEL	POST-DEVELOPMENT PEAK FLOWS (m ³ /s)					
	2 Year	5 Year	10 Year	25 Year	50 Year	100 Year
P1	0.017	0.022	0.025	0.032	0.039	0.045
P2	0.013	0.017	0.020	0.026	0.031	0.036
P3	0.038	0.049	0.057	0.073	0.088	0.101
101	0.004	0.006	0.007	0.009	0.010	0.012
102	0.002	0.002	0.003	0.004	0.004	0.005
201	0.004	0.005	0.006	0.008	0.009	0.011
202	0.004	0.005	0.006	0.008	0.009	0.011
203	0.015	0.020	0.023	0.029	0.035	0.038
204	0.004	0.006	0.007	0.009	0.010	0.012
205	0.005	0.006	0.007	0.009	0.011	0.013
P4	0.015	0.019	0.022	0.029	0.035	0.040
Total	0.083	0.108	0.126	0.160	0.193	0.222



Table 6: Post-Development Runoff Rates by Outlet

OUTLET	POST-DEVELOPMENT PEAK FLOWS (m ³ /s)					
	2 Year	5 Year	10 Year	25 Year	50 Year	100 Year
Maple Street	0.013	0.017	0.020	0.026	0.031	0.036
Fifth Street	0.023	0.030	0.035	0.045	0.053	0.062
Sixth Street	0.047	0.061	0.071	0.092	0.108	0.123
Total	0.083	0.108	0.126	0.160	0.193	0.222

Post-development runoff directed to Fifth Street has decreased from pre-development conditions and as such, no quantity controls are necessary for the Fifth Street outlet. As depicted on Drawing DP-2, efforts have been taken to minimize the size of Drainage Area P2 and thus minimize sheet flows to Maple Street. The proposed condition for Drainage Area P2 reflects the precedent for existing residential properties adjacent to the development.

Post-development flows have increased for the Sixth Street outlet, necessitating the need for quantity controls. The Modified Rational Method was employed to compute storage volumes required to match post-development flows to pre-development flows. This calculation is presented in Appendix C, which concludes 18 m³ of storage is required to control the 5-year storm and 37 m³ of storage is required to control the 100-year storm. 75 mm diameter orifices will be installed immediately upstream of the north inlet of OGS1 and the west inlet of CBMH405. Storm sewer pipes and structures upstream of these orifices provide the necessary 18 m³ of storage to control the 5-year storm event without storm sewer surcharge. The remaining 19 m³ of storage to control the 100-year storm event will be provided as ponding within the asphalt area of the condominium block. Ponding will occur to an elevation of 185.24 m before spilling overland onto the Maple Street roadway. The maximum ponding depth on the development site is 0.16 m and the ponding area is illustrated on Drawings SG-1, DP-2 and STM-1. Major post-development stormwater runoff from the property will drain overland along the proposed internal access road and spill onto Maple Street then continue to be conveyed along the adjacent streets which ultimately outlet to Georgian Bay.

Storm sewer sizing calculations for Drainage Area P3 (101-102 and 201-205) are provided in Appendix B. Note all pipes are only required to be 250 mm diameter, but have been upsized to increase the available underground storage in the system.



Table 7 presents the storage in the Sixth Street outlet and the orifice discharge for varying water levels. Orifice discharge calculations are shown in Appendix D.

Table 7: Storage Volume & Orifice Discharge for Sixth Street

WATER LEVEL (m)	JNDERGROUND STORAGE VOLUME (m ³)	ABOVEGROUND STORAGE VOLUME (m ³)	OGS1 ORIFICE DISCHARGE (m ³ /s)	CBMH405 ORIFICE DISCHARGE (m ³ /s)
184.04	2	0	0.000	0.000
184.14	3	0	0.003	0.005
184.24	4	0	0.006	0.007
184.34	5	0	0.008	0.008
184.44	9	0	0.009	0.010
184.54	11	0	0.010	0.011
184.64	15	0	0.011	0.012
184.74	16	0	0.012	0.013
184.84	16	0	0.013	0.014
184.94	17	0	0.014	0.015
185.04	18	0	0.015	0.016
185.14	18	1	0.016	0.016
185.24	18	19	0.017	0.017

4.4 STORMWATER QUALITY

Lawn areas and landscaping along internal flow routes will promote infiltration and sediment removal prior to discharging into the municipal street and storm sewer system. Drainage Area P3 will be collected in the internal storm sewer system. Drainage Areas 101-102 collect runoff from landscaped and roof areas while Drainage Areas 201-205 collect runoff from landscaped, roof and paved areas. Runoff from grassed areas and roofs is considered clean. However, runoff from paved areas including the condominium access road require treatment prior to being discharged off-site. Therefore, runoff from Drainage Areas 201-2035 will pass through a Stormceptor oil grit separator prior to entering the existing storm sewer system on Sixth Street



to provide quality control to the effluent. The Stormceptor was sized using the PCSWMM Sizing Tool provided by the Stormceptor manufacturer, Imbrium Systems. The results of the sizing tool are presented in Appendix E along with a detail of the specified Stormceptor (EF4). The Stormceptor along with the landscaped areas will provide enhanced (Level 1) protection as outlined by MECP guidelines.



5 Siltation & Erosion Control

Siltation and erosion control measures will be implemented for all construction activities occurring at the site including topsoil stripping, material stockpiling, road construction, grading operations and house construction. In order to minimize environmental impacts, the following erosion and sediment control measures will be enforced before, during and after construction:

- disturbance activities will be minimized where possible;
- silt fence will be installed before construction to control movement and deposition of sediment;
- construction vehicle access will be limited and the site entrance will be constructed with a stone mud mat to minimize off-site tracking of material; and
- a re-vegetation strategy for landscaped areas will be implemented immediately after construction is completed.

Erosion and sediment control measures will be implemented before the outset of construction activities and will be inspected every two weeks or after storm events with rainfall depths greater than 25 millimetres. Repairs to the control measures will be made as necessary and additional control measures will be provided as required. Drawing EC-1 outlines the proposed siltation and erosion control strategy for the site.



6 Summary

The proposed stormwater management plan presented in this report confirms that the proposed development can proceed without adversely impacting the drainage surrounding the site. Raising the grades and constructing curbs along the development side of Maple Street will improve the poor drainage conditions in the area. Stormwater will be conveyed through a Stormceptor EF4 prior to entering the Sixth Street storm sewer in order to provide enhanced (Level 1) stormwater quality. Appropriate siltation and erosion control measures will be implemented to ensure minimal sediment transfer from the development occurs during construction.



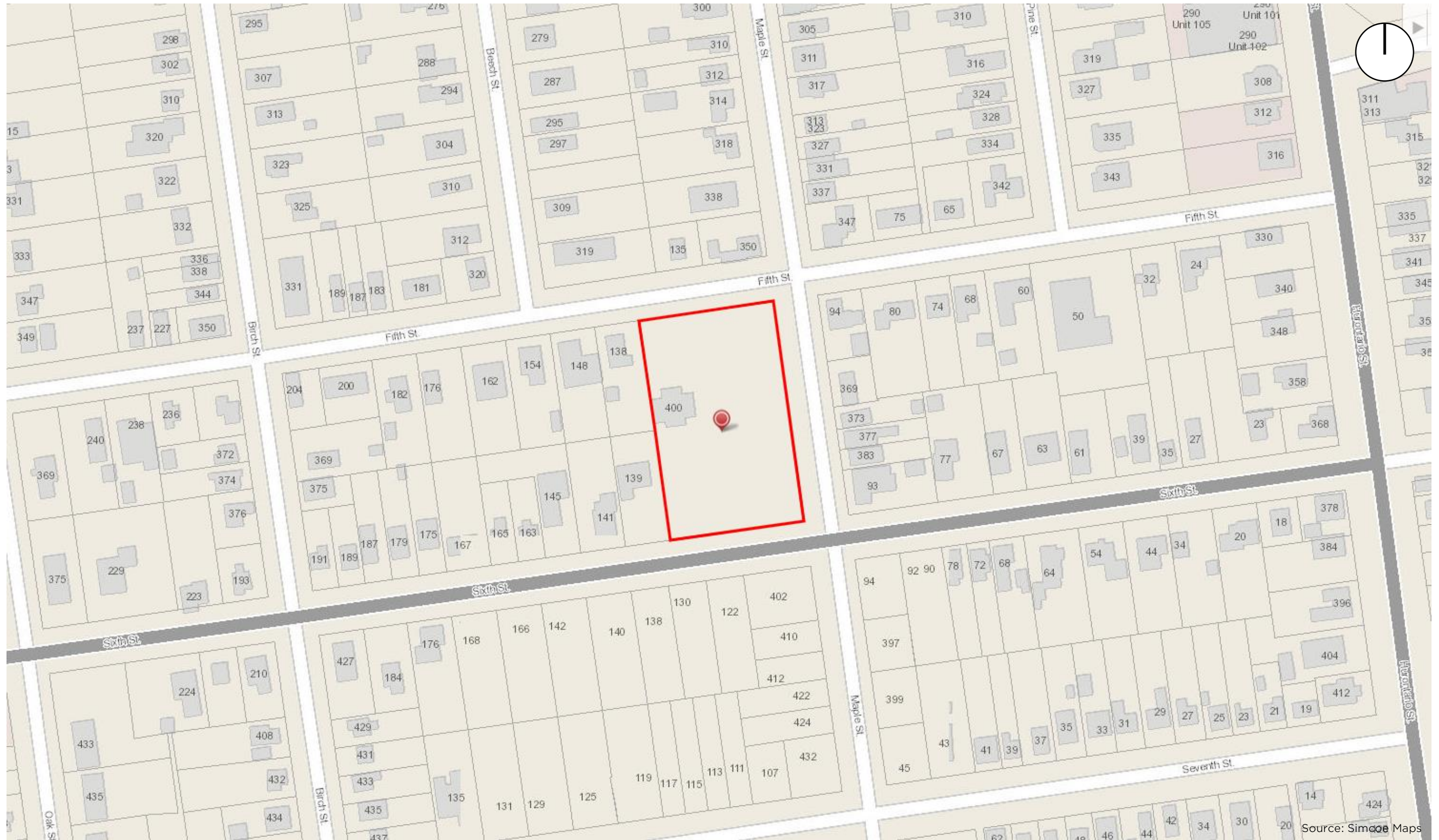

Source: Simcoe Maps

VICTORIA ANNEX

Figure 1: Site Location - Map



SITE STATISTICS
 ZONE R3-38
 USE CONDO/SUBDIVISION
 MUNICIPAL ADDRESS 400 MAPLE STREET, COLLINGWOOD
 PARKING PROVIDED 2 PER UNIT PLUS 1 ACCESSIBLE

SUBJECT LANDS
 PROPERTY AREA 6011 m²
 PROPOSED UNITS 19
 MAXIMUM DENSITY 19 UNITS

SINGLE DETACHED - 4 LOTS
 GFA 379.8 m² (4,087.9 ft²) MINIMUM

SEMI DETACHED - 10 UNITS
 GFA 350.1 m² (3,768.4 ft²) MINIMUM

TOWNHOME - 3 UNITS (COACH HOUSE)
 ABOVE 6 PARKING SPACES

VICTORIA ANNEX SEMI DETACHED - 2 UNITS

NOTES
 1. LEGAL SURVEY COMPLETED BY J.D. BARNES DATED NOVEMBER 11, 2020.
 2. SNOW TO BE PLOWED AND HAULED OFF-SITE FOR THE CONDOMINIUM BLOCK.

PROVISION	SINGLES		SEMIS		GROUP/CLUSTER 'R3'	
	'R3' REQUIRED	PROPOSED	'R3' REQUIRED	PROPOSED	'R3' REQUIRED	PROPOSED
NUMBER OF UNITS	4	10	4	10	5	5
LOT AREA (MIN)	325 m ²	381.0 m ²	275 m ²	263.1 m ²	NIL	1832.2 m ²
LOT FRONTAGE	10.0 m	13.9 m	9.0 m	9.6 m	NIL	13.6 m
FRONT YARD	4.5 m	4.5 m	4.5 m	4.5 m	6.0 m	42.6 m
EXTERIOR SIDE YARD	4.5 m	4.7 m	4.5 m	N/A	6.0 m	N/A
INTERIOR SIDE YARD	1.2 m	1.2 m	1.2 m & 0.0	1.2 m & 0.0	6.0 m	2.0-2.5 m
REAR YARD	7.5 m	7.4 m	7.5 m	7.2 m	7.5 m	0.02 m
HEIGHT (MAX)	12.0 m	11.3 m	12.0 m	12.0 m	15.0 m	14.3 m
COVERAGE (MAX)	40%	44%	40%	46%	40%	34%
LANDSCAPED AREA (MIN)	35%	47%	35%	41%	40%	32%
PARKING SPACES	2/UNIT	2/UNIT	2/UNIT	2/UNIT	2/UNIT	8 TOTAL (INCL. 1 VISITOR)
ACCESSIBLE PARKING					1	
ACCESSORY BUILDING		GARAGE			GARAGE	PAVILION
NUMBER ACC. BUILDINGS		2			1	1
INTERIOR SIDE YARD	1.0 m	1.6 m			1.0 m	0.6 m
REAR YARD	1.0 m	1.8 m			1.0 m	1.2 m
SETBACK TO BLDGS	2.0 m	2.0 m			2.0 m	2.4 m
COVERAGE (MAX)	15%	6%			15%	4.2%
GROUND AREA (MAX)	75 m ²	22.4 m ²			200 m ²	77.3 m ²
HEIGHT (MAX)	7.0 m	5.2 m			7.0 m	5.6 m

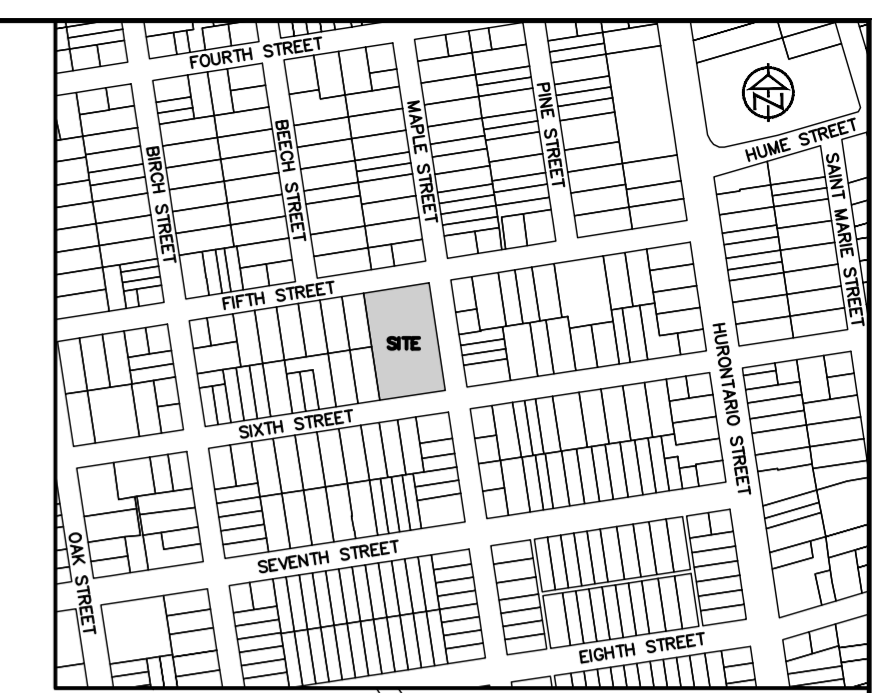
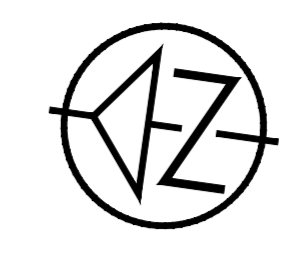

KEY PLAN
NTS

MAPLE STREET

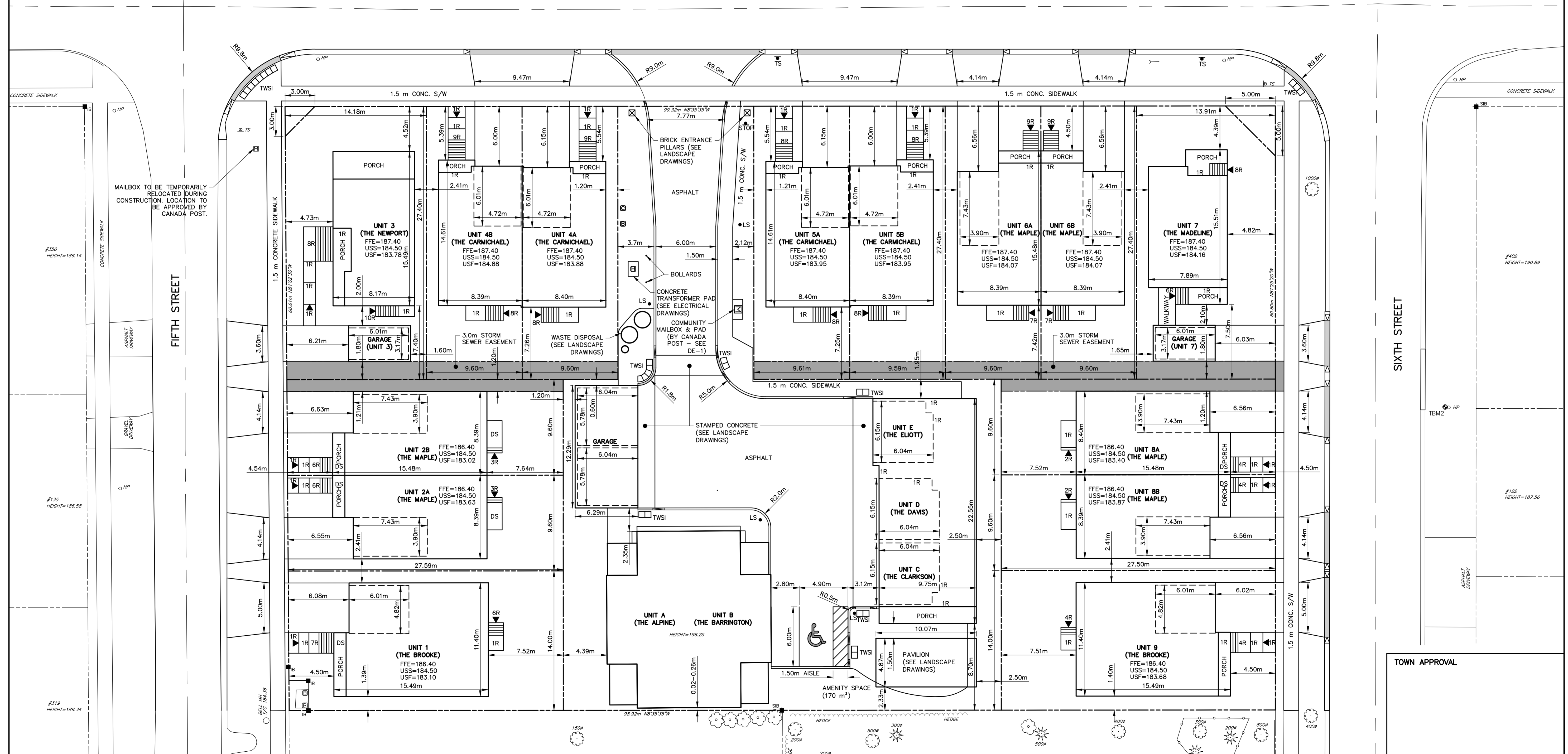

DISCLAIMER AND COPYRIGHT
 CONTRACTOR MUST VERIFY ALL DIMENSIONS AND BE RESPONSIBLE FOR SAME. ANY DISCREPANCIES MUST BE REPORTED TO THE ENGINEER BEFORE COMMENCING WORK. DRAWINGS ARE NOT TO BE SCALED.
 TATHAM ENGINEERING LIMITED CLAIMS COPYRIGHT TO THIS DRAWING WHICH MAY NOT BE USED FOR ANY PURPOSE OTHER THAN THAT PROVIDED IN THE CONTRACT BETWEEN THE OWNER/CLIENT AND THE ENGINEER WITHOUT THE EXPRESS CONSENT OF TATHAM ENGINEERING LIMITED.

BENCHMARKS
 TBM1 - ELEVATION 181.18
 #010840957 RIB WITH BRONZE CAP AT SOUTHEAST CORNER OF HIGH AND SIXTH STREET ON GRASS BOULEVARD APPROXIMATELY 0.30 m SOUTH OF SOUTH EDGE OF CURB.
 TBM2 - ELEVATION 185.79
 NAIL AND WASHER IN NORTH FACE OF HYDRO POLE LOCATED ON SOUTH SIDE OF SIXTH STREET APPROXIMATELY 40 m WEST OF INTERSECTION OF SIXTH STREET AND MAPLE STREET.

NOTES
 ALL DIMENSIONS, ELEVATIONS AND SIZES ARE IN METRIC UNITS UNLESS INDICATED. PIPE SIZES ARE IN MILLIMETRES UNLESS OTHERWISE INDICATED. ELEVATIONS ARE IN METRES UNLESS INDICATED.

No.	REVISION DESCRIPTION	DATE	ENGINEER STAMP
1.	FIRST SUBMISSION TO TOWN	NOV 2020	
2.	SECOND SUBMISSION TO TOWN	APR 2021	
3.	SECOND SUBMISSION TO TOWN - REVISED	JUN 2021	
4.	THIRD SUBMISSION TO TOWN	OCT 2021	

VICTORIA ANNEX
GEORGIAN COMMUNITIES
TOWN OF COLLINGWOOD

SITE PLAN

TATHAM ENGINEERING
 DESIGN: KRS/MJF FILE: 120174 DWG:
 DRAWN: MJF DATE: SEP 2020 **SP-1**
 CHECK: KRS SCALE: 1:200 Sheet No. 5 of 9

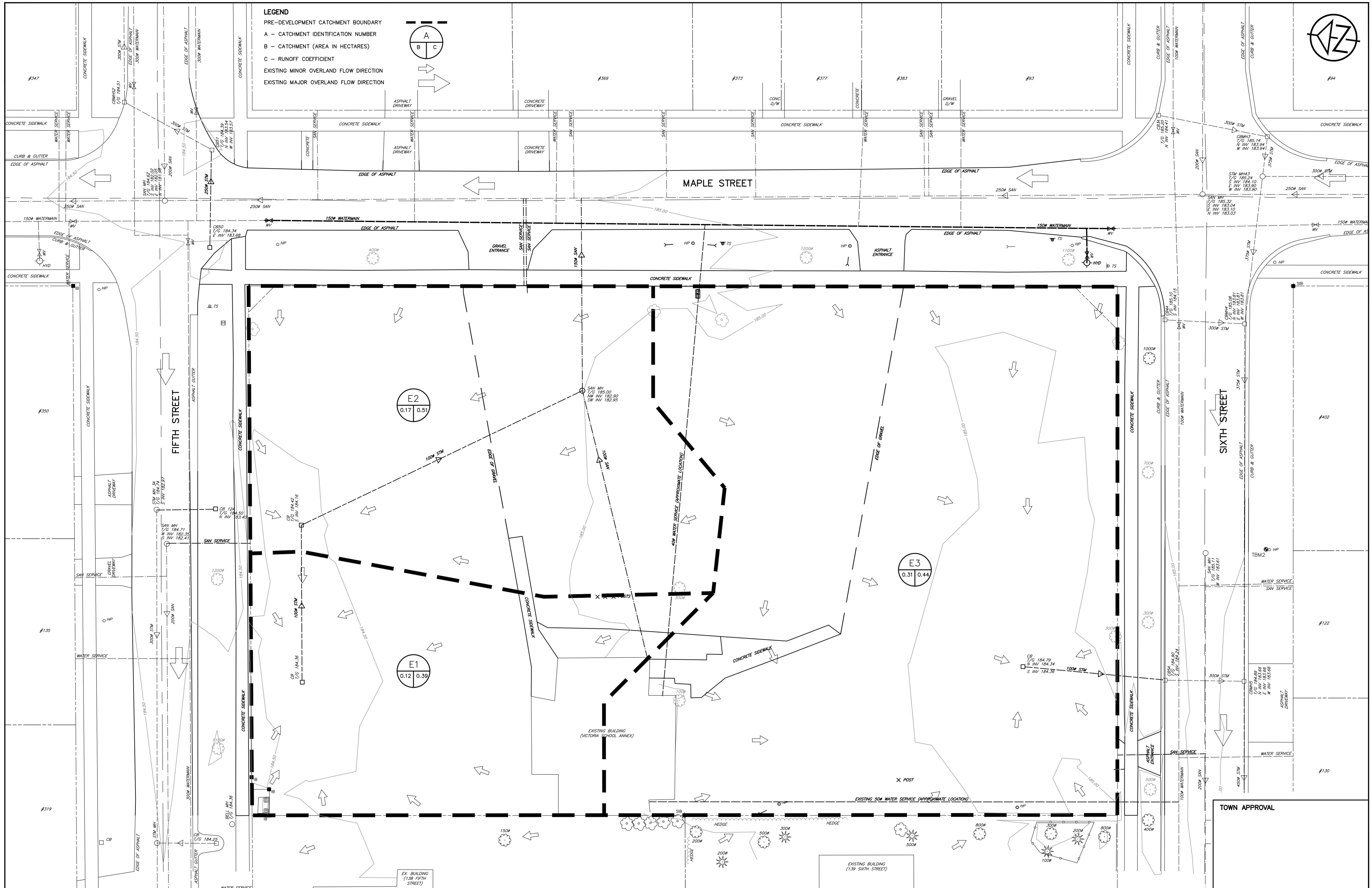

DISCLAIMER AND COPYRIGHT
 CONTRACTOR MUST VERIFY ALL DIMENSIONS AND BE RESPONSIBLE FOR SAME. ANY DISCREPANCIES MUST BE REPORTED TO THE ENGINEER BEFORE COMMENCING WORK. DRAWINGS ARE NOT TO BE SCALED.
 TATHAM ENGINEERING LIMITED CLAIMS COPYRIGHT TO THIS DRAWING WHICH MAY NOT BE USED FOR ANY PURPOSE OTHER THAN THAT PROVIDED IN THE CONTRACT BETWEEN THE OWNER/CLIENT AND THE ENGINEER WITHOUT THE EXPRESS CONSENT OF TATHAM ENGINEERING LIMITED.

BENCHMARKS
 BM1 - ELEVATION 181.18
 #101840957 RIB WITH BRONZE CAP AT SOUTHEAST CORNER OF HIGH AND SIXTH STREET ON GRASS BOULEVARD APPROXIMATELY 0.30 m SOUTH OF EDGE OF CURB.
 BM2 - ELEVATION 185.79
 NAIL AND WASHER IN NORTH FACE OF HYDRO POLE LOCATED ON SOUTH SIDE OF SIXTH STREET APPROXIMATELY 40 m WEST OF INTERSECTION OF SIXTH STREET AND MAPLE STREET.

NOTES
 ALL DIMENSIONS, ELEVATIONS AND SIZES ARE IN METRIC UNITS UNLESS INDICATED. PIPE SIZES ARE IN MILLIMETRES UNLESS OTHERWISE INDICATED. ELEVATIONS ARE IN METRES UNLESS INDICATED.

No.	REVISION DESCRIPTION	DATE
1.	FIRST SUBMISSION TO TOWN	NOV 2020
2.	SECOND SUBMISSION TO TOWN	APR 2021
3.	SECOND SUBMISSION TO TOWN - REVISED	JUN 2021
4.	THIRD SUBMISSION TO TOWN	OCT 2021

ENGINEER STAMP

VICTORIA ANNEX
GEORGIAN COMMUNITIES
TOWN OF COLLINGWOOD
 PRE-DEVELOPMENT
 DRAINAGE PLAN

TATHAM ENGINEERING
 DESIGN: KRS/MJF FILE: 120174 DWG:
 DRAWN: MJF DATE: SEP 2020 **DP-1**
 CHECK: KRS SCALE: 1:200

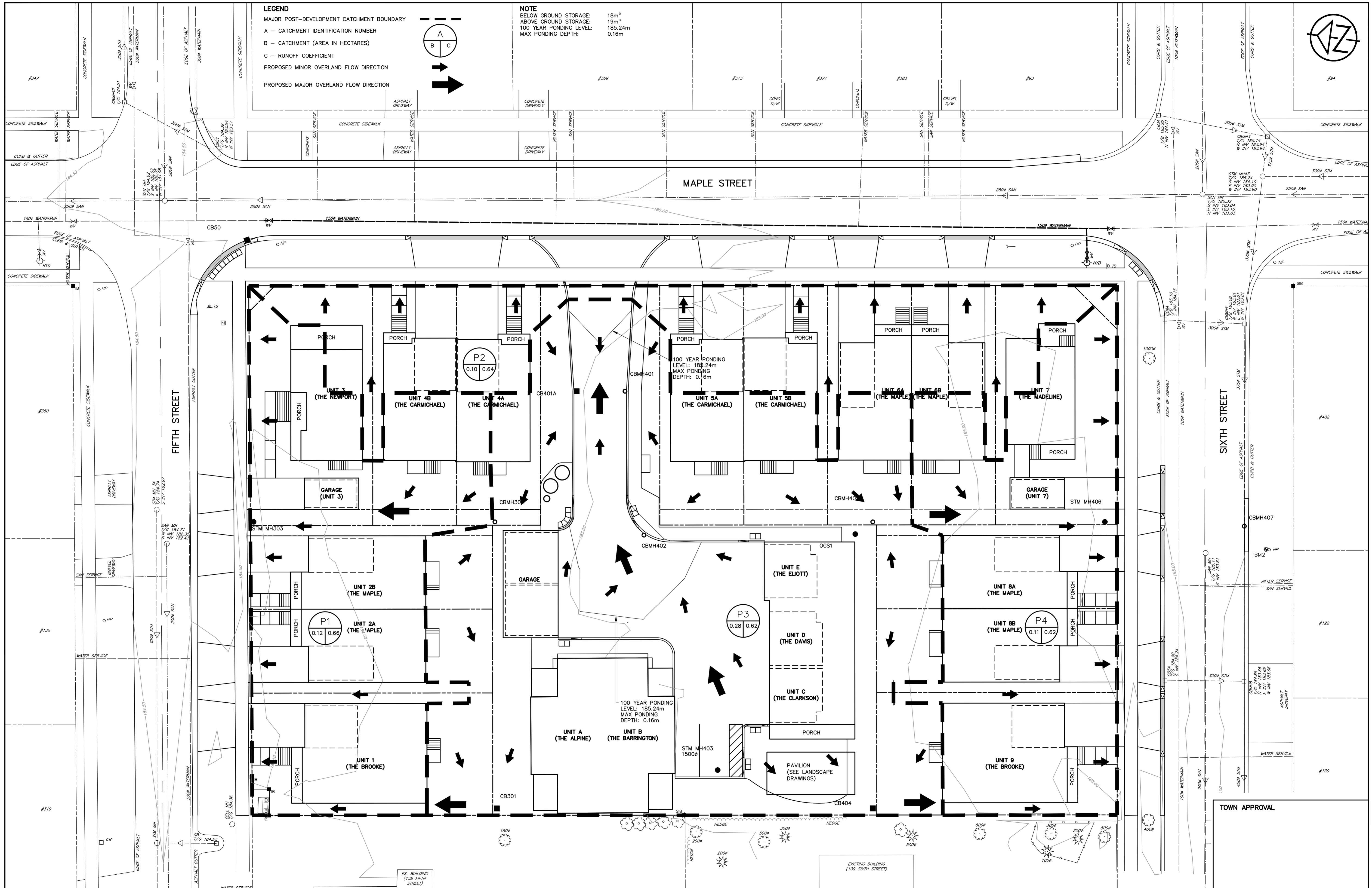

DISCLAIMER AND COPYRIGHT
 CONTRACTOR MUST VERIFY ALL DIMENSIONS AND BE RESPONSIBLE FOR SAME. ANY DISCREPANCIES MUST BE REPORTED TO THE ENGINEER BEFORE COMMENCING WORK. DRAWINGS ARE NOT TO BE SCALED.
 TATHAM ENGINEERING LIMITED CLAIMS COPYRIGHT TO THIS DRAWING WHICH MAY NOT BE USED FOR ANY PURPOSE OTHER THAN THAT PROVIDED IN THE CONTRACT BETWEEN THE OWNER/CLIENT AND THE ENGINEER WITHOUT THE EXPRESS CONSENT OF TATHAM ENGINEERING LIMITED.

BENCHMARKS
 TBM1 - ELEVATION 181.18
 #101840957 RIB WITH BRONZE CAP AT SOUTHEAST CORNER OF HIGH AND SIXTH STREET ON GRASS BOULEVARD APPROXIMATELY 0.30 m SOUTH OF EDGE OF CURB.
 TBM2 - ELEVATION 185.79
 NAIL AND WASHER IN NORTH FACE OF HYDRO POLE LOCATED ON SOUTH SIDE OF SIXTH STREET APPROXIMATELY 40 m WEST OF INTERSECTION OF SIXTH STREET AND MAPLE STREET.

NOTES
 ALL DIMENSIONS, ELEVATIONS AND SIZES ARE IN METRIC UNITS UNLESS INDICATED. PIPE SIZES ARE IN MILLIMETRES UNLESS OTHERWISE INDICATED. ELEVATIONS ARE IN METRES UNLESS INDICATED.

No.	REVISION DESCRIPTION	DATE
1.	FIRST SUBMISSION TO TOWN	NOV 2020
2.	SECOND SUBMISSION TO TOWN	APR 2021
3.	SECOND SUBMISSION TO TOWN - REVISED	JUN 2021
4.	THIRD SUBMISSION TO TOWN	OCT 2021

ENGINEER STAMP

VICTORIA ANNEX
GEORGIAN COMMUNITIES
TOWN OF COLLINGWOOD
POST-DEVELOPMENT
DRAINAGE PLAN

TATHAM ENGINEERING
 DESIGN: KRS/MJF FILE: 120174 DWG:
 DRAWN: MJF DATE: SEP 2020 **DP-2**
 CHECK: KRS SCALE: 1:200

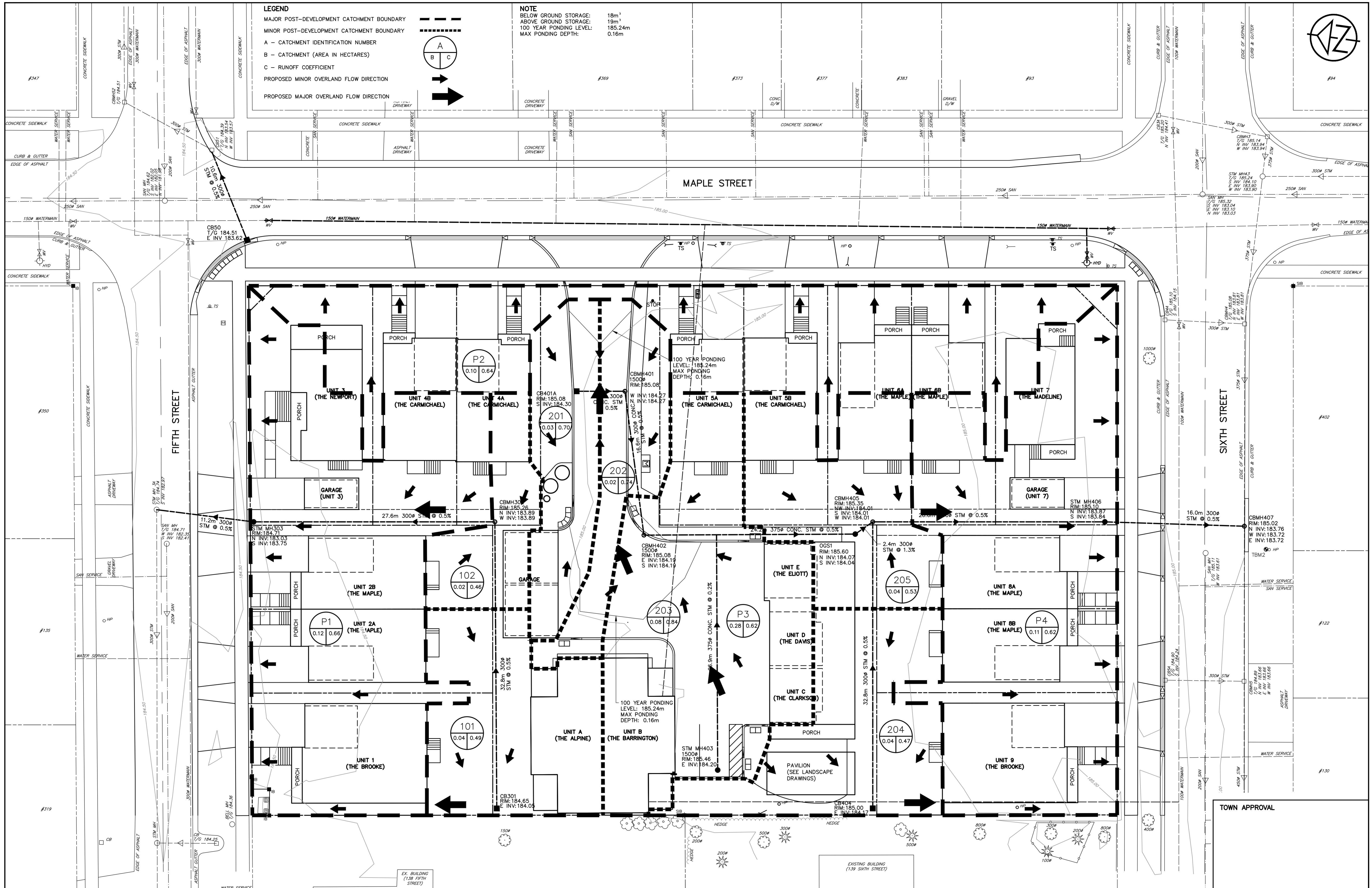

LEGEND

MAJOR POST-DEVELOPMENT CATCHMENT BOUNDARY
 MINOR POST-DEVELOPMENT CATCHMENT BOUNDARY
 A - CATCHMENT IDENTIFICATION NUMBER
 B - CATCHMENT (AREA IN HECTARES)
 C - RUNOFF COEFFICIENT
 PROPOSED MINOR OVERLAND FLOW DIRECTION
 PROPOSED MAJOR OVERLAND FLOW DIRECTION

NOTE

BELOW GROUND STORAGE: 18m³
 ABOVE GROUND STORAGE: 19m³
 100 YEAR PONDING LEVEL: 185.24m
 MAX PONDING DEPTH: 0.16m

DISCLAIMER AND COPYRIGHT

CONTRACTOR MUST VERIFY ALL DIMENSIONS AND BE RESPONSIBLE FOR SAME. ANY DISCREPANCIES MUST BE REPORTED TO THE ENGINEER BEFORE COMMENCING WORK. DRAWINGS ARE NOT TO BE SCALED.

TATHAM ENGINEERING LIMITED CLAIMS COPYRIGHT TO THIS DRAWING WHICH MAY NOT BE USED FOR ANY PURPOSE OTHER THAN THAT PROVIDED IN THE CONTRACT BETWEEN THE OWNER/CLIENT AND THE ENGINEER WITHOUT THE EXPRESS CONSENT OF TATHAM ENGINEERING LIMITED.

BENCHMARKS

BM1 - ELEVATION 181.18
 #010840957 RIB WITH BRONZE CAP AT SOUTHEAST CORNER OF HIGH AND SIXTH STREET ON GRASS BOULEVARD APPROXIMATELY 0.30 m SOUTH OF EDGE OF CURB.

BM2 - ELEVATION 185.79
 NAIL AND WASHER IN NORTH FACE OF HYDRO POLE LOCATED ON SOUTH SIDE OF SIXTH STREET APPROXIMATELY 40 m WEST OF INTERSECTION OF SIXTH STREET AND MAPLE STREET.

NOTES

ALL DIMENSIONS, ELEVATIONS AND SIZES ARE IN METRIC UNITS UNLESS INDICATED. PIPE SIZES ARE IN MILLIMETRES UNLESS OTHERWISE INDICATED. ELEVATIONS ARE IN METRES UNLESS INDICATED.

No.	REVISION DESCRIPTION	DATE
1.	FIRST SUBMISSION TO TOWN	NOV 2020
2.	SECOND SUBMISSION TO TOWN	APR 2021
3.	SECOND SUBMISSION TO TOWN - REVISED	JUN 2021
4.	THIRD SUBMISSION TO TOWN	OCT 2021

ENGINEER STAMP

VICTORIA ANNEX
GEORGIAN COMMUNITIES
TOWN OF COLLINGWOOD

STORM SEWER
CATCHMENT PLAN

TATHAM ENGINEERING

DESIGN: KRS/MJF
 DRAWN: MJF
 CHECK: KRS

FILE: 120174
 DATE: SEP 2020
 SCALE: 1:200

DWG: **STM-1**

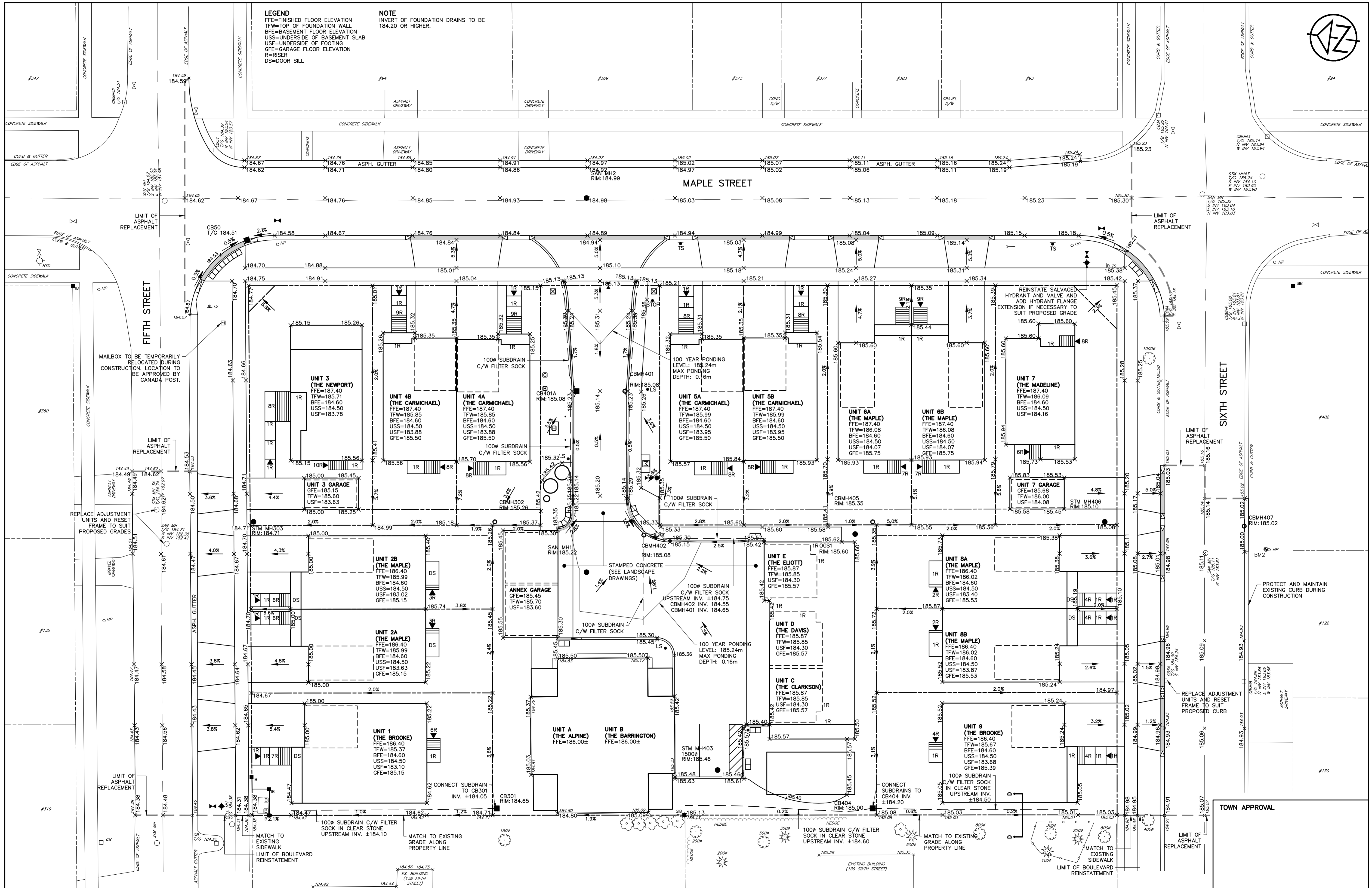

DISCLAIMER AND COPYRIGHT
 CONTRACTOR MUST VERIFY ALL DIMENSIONS AND BE RESPONSIBLE FOR SAME. ANY DISCREPANCIES MUST BE REPORTED TO THE ENGINEER BEFORE COMMENCING WORK. DRAWINGS ARE NOT TO BE SCALED.
 TATHAM ENGINEERING LIMITED CLAIMS COPYRIGHT TO THIS DRAWING WHICH MAY NOT BE USED FOR ANY PURPOSE OTHER THAN THAT PROVIDED IN THE CONTRACT BETWEEN THE OWNER/CLIENT AND THE ENGINEER WITHOUT THE EXPRESS CONSENT OF TATHAM ENGINEERING LIMITED.

BENCHMARKS
 TBM1 - ELEVATION 181.18
 #010840957 RIB WITH BRONZE CAP AT SOUTHEAST CORNER OF HIGH AND SIXTH STREET ON GRASS BOULEVARD APPROXIMATELY 0.30 m SOUTH OF EDGE OF CURB.
 TBM2 - ELEVATION 185.79
 NAIL AND WASHER IN NORTH FACE OF HYDRO POLE LOCATED ON SOUTH SIDE OF SIXTH STREET APPROXIMATELY 40 m WEST OF INTERSECTION OF SIXTH STREET AND MAPLE STREET.

NOTES
 ALL DIMENSIONS, ELEVATIONS AND SIZES ARE IN METRIC UNITS UNLESS INDICATED. PIPE SIZES ARE IN MILLIMETRES UNLESS OTHERWISE INDICATED. ELEVATIONS ARE IN METRES UNLESS INDICATED.

No.	REVISION DESCRIPTION	DATE	ENGINEER STAMP
1.	FIRST SUBMISSION TO TOWN	NOV 2020	
2.	SECOND SUBMISSION TO TOWN	APR 2021	
3.	SECOND SUBMISSION TO TOWN - REVISED	JUN 2021	
4.	THIRD SUBMISSION TO TOWN	OCT 2021	

VICTORIA ANNEX
GEORGIAN COMMUNITIES
TOWN OF COLLINGWOOD

TATHAM ENGINEERING

DESIGN: KRS/MJF
 DRAWN: MJF
 CHECK: KRS
 FILE: 120174
 DATE: SEP 2020
 SCALE: 1:200
 DWG: **SG-1**
 Sheet No. 8 of 10

Appendix A: Pre-Development Runoff Calculations

Appendix B: Post-Development Runoff Calculations

Project Information

Victoria Annex	120174
----------------	--------

Drawing Reference

120174-DP02, 120174-STM01, 120174-SS01	October 06-21
--	---------------

Prepared By

MJF	October 06-21
-----	---------------

Reviewed By

KRS	October 06-21
-----	---------------

Engineer's Stamp

Municipality

Town of Collingwood

Design Storm

5 year

Time of Concentration

10 mins

IDF Curve Coefficients

Year	5
A	1135.40
B	7.50
C	0.84

Manning's Coefficient

Pipe	Value
CSP	0.024
Conc.	0.013
PVC	0.013

STREET NAME	AREA LABEL / ID	UPSTREAM MANHOLE	DOWNSTREAM MANHOLE	TRIBUTARY AREA (ha)	RUNOFF COEFFICIENT	AREA x RUNOFF COEFFICIENT	CUMULATIVE AREA (ha)	CUMULATIVE AREA x RUNOFF COEFFICIENT	TIME OF CONCENTRATION (min.)	RAINFALL INTENSITY (mm/hr)	PEAK FLOW (m ³ /s)	MANNING'S ROUGHNESS COEFFICIENT	PIPE LENGTH (m)	SLOPE (%)	ACTUAL PIPE DIAMETER (mm)	FULL FLOW VELOCITY (m/s)	FULL FLOW CAPACITY (m ³ /s)	ACTUAL VELOCITY (m/s)	TRAVEL TIME (min.)	CALCULATED PIPE DIAMETER (mm)	PERCENT OF FULL FLOW (%)	TOTAL TIME OF TRAVEL (min.)
Fifth Street	101	CB301	CBMH302	0.041	0.49	0.020	0.041	0.020	10.000	102.271	0.006	0.013	32.8	0.5%	300	0.97	0.068	0.56	0.98	118	8.4%	10.98
Fifth Street	102	CBMH302	STM MH303	0.019	0.46	0.009	0.060	0.029	10.982	97.682	0.008	0.013	27.6	0.5%	300	0.97	0.068	0.61	0.76	133	11.4%	11.74
Fifth Street	-	STM MH303	STM MH3A	0.000	0.00	0.000	0.060	0.029	11.742	94.427	0.008	0.013	11.2	0.5%	300	0.97	0.068	0.60	0.31	131	11.1%	12.05
Sixth Street	201	CB401A	CBMH401	0.026	0.70	0.018	0.026	0.018	10.000	102.271	0.005	0.013	5.5	0.5%	300	0.97	0.068	0.54	0.17	115	7.7%	10.17
Sixth Street	202	CBMH401	CBMH402	0.025	0.74	0.018	0.051	0.037	10.169	101.450	0.010	0.013	16.6	0.5%	300	0.97	0.068	0.65	0.42	148	15.2%	10.59
Sixth Street	203	CBMH402	OGS1	0.082	0.84	0.069	0.133	0.106	10.592	99.452	0.029	0.013	24.2	0.5%	375	1.12	0.124	0.85	0.47	218	23.6%	11.06
Sixth Street	-	STM MH403	MAIN	0.000	0.00	0.000	0.000	0.000	0.000	208.556		0.013	26.9	0.2%	375							
Sixth Street	204	CB404	CBMH405	0.044	0.47	0.021	0.044	0.021	10.000	102.271	0.006	0.013	32.8	0.5%	300	0.97	0.068	0.56	0.98	119	8.5%	10.98
Sixth Street	-	OGS1	CBMH405	0.000	0.00	0.000	0.133	0.106	11.063	97.321	0.029	0.013	2.4	1.3%	300	1.56	0.110	1.22	0.03	181	25.9%	11.10
Sixth Street	205	CBMH405	STM MH406	0.042	0.53	0.022	0.219	0.149	11.096	97.177	0.040	0.013	26.6	0.5%	300	0.97	0.068	0.94	0.47	246	58.7%	11.57
Sixth Street	-	STM MH406	CBMH407	0.000	0.00	0.000	0.219	0.149	11.567	95.155	0.039	0.013	16.0	0.5%	300	0.97	0.068	0.94	0.28	244	57.4%	11.85

Rational Method Calculation

Project Details

Victoria Annex	120174
----------------	--------

Prepared By

MJF	October 1, 2021
-----	-----------------

Municipality

Town of Collingwood

Pre-Development Analysis

Catchment ID:	
Catchment Area (ha):	
Runoff Coefficient:	
Time of Concentration (min):	

Post-Development Analysis

Catchment ID:	101
Catchment Area (ha):	0.04
Runoff Coefficient:	0.49
Time of Concentration (min):	10.00

Design Storm	Pre-Development						Design Storm	Post-Development						
	2YR	5YR	10YR	25YR	50YR	100YR		Controlled	Uncontrolled					
A	807	1135	1387	1676	1973	2193	i (mm/hr)	166	209	237	273	293	322	
B	6.75	7.50	7.97	8.30	9.00	9.04	0	Runoff C	0.00	0.00	0.00	0.00	0.00	0.00
C	0.83	0.84	0.85	0.86	0.87	0.87		Q (m ³ /s)	0.000	0.000	0.000	0.000	0.000	0.000
i (mm/hr)	166	209	237	273	293	322		i (mm/hr)	78	102	118	138	153	168
Runoff C	0.00	0.00	0.00	0.00	0.00	0.00	101	Runoff C	0.49	0.49	0.49	0.54	0.58	0.61
Q (m ³ /s)	0.000	0.000	0.000	0.000	0.000	0.000		Q (m ³ /s)	0.004	0.006	0.007	0.009	0.010	0.012

Rational Method Calculation

Project Details

Victoria Annex	120174
----------------	--------

Prepared By

MJF	October 1, 2021
-----	-----------------

Municipality

Town of Collingwood

Pre-Development Analysis

Catchment ID:	
Catchment Area (ha):	
Runoff Coefficient:	
Time of Concentration (min):	

Post-Development Analysis

	Controlled	Uncontrolled
Catchment ID:		102
Catchment Area (ha):		0.02
Runoff Coefficient:		0.46
Time of Concentration (min):		10.00

Design Storm	Pre-Development						Design Storm	Post-Development						
	2YR	5YR	10YR	25YR	50YR	100YR		2YR	5YR	10YR	25YR	50YR	100YR	
A	807	1135	1387	1676	1973	2193	i (mm/hr)	166	209	237	273	293	322	
B	6.75	7.50	7.97	8.30	9.00	9.04	0	Runoff C	0.00	0.00	0.00	0.00	0.00	0.00
C	0.83	0.84	0.85	0.86	0.87	0.87		Q (m ³ /s)	0.000	0.000	0.000	0.000	0.000	0.000
i (mm/hr)	166	209	237	273	293	322		i (mm/hr)	78	102	118	138	153	168
Runoff C	0.00	0.00	0.00	0.00	0.00	0.00	102	Runoff C	0.46	0.46	0.46	0.51	0.55	0.58
Q (m ³ /s)	0.000	0.000	0.000	0.000	0.000	0.000		Q (m ³ /s)	0.002	0.002	0.003	0.004	0.004	0.005

Rational Method Calculation

Project Details

Victoria Annex	120174
----------------	--------

Prepared By

MJF	October 1, 2021
-----	-----------------

Municipality

Town of Collingwood

Pre-Development Analysis

Catchment ID:	
Catchment Area (ha):	
Runoff Coefficient:	
Time of Concentration (min):	

Post-Development Analysis

Catchment ID:	201
Catchment Area (ha):	0.03
Runoff Coefficient:	0.70
Time of Concentration (min):	10.00

Design Storm	Pre-Development						Design Storm	Post-Development						
	2YR	5YR	10YR	25YR	50YR	100YR		Controlled	Uncontrolled					
A	807	1135	1387	1676	1973	2193	i (mm/hr)	166	209	237	273	293	322	
B	6.75	7.50	7.97	8.30	9.00	9.04	0	Runoff C	0.00	0.00	0.00	0.00	0.00	0.00
C	0.83	0.84	0.85	0.86	0.87	0.87		Q (m ³ /s)	0.000	0.000	0.000	0.000	0.000	0.000
i (mm/hr)	166	209	237	273	293	322		i (mm/hr)	78	102	118	138	153	168
Runoff C	0.00	0.00	0.00	0.00	0.00	0.00	201	Runoff C	0.70	0.70	0.70	0.77	0.84	0.88
Q (m ³ /s)	0.000	0.000	0.000	0.000	0.000	0.000		Q (m ³ /s)	0.004	0.005	0.006	0.008	0.009	0.011

Rational Method Calculation

Project Details

Victoria Annex	120174
----------------	--------

Prepared By

MJF	October 1, 2021
-----	-----------------

Municipality

Town of Collingwood

Pre-Development Analysis

Catchment ID:	
Catchment Area (ha):	
Runoff Coefficient:	
Time of Concentration (min):	

Post-Development Analysis

Catchment ID:	202
Catchment Area (ha):	0.02
Runoff Coefficient:	0.74
Time of Concentration (min):	10.00

Design Storm	Pre-Development						Design Storm	Post-Development						
	2YR	5YR	10YR	25YR	50YR	100YR		2YR	5YR	10YR	25YR	50YR	100YR	
A	807	1135	1387	1676	1973	2193	i (mm/hr)	166	209	237	273	293	322	
B	6.75	7.50	7.97	8.30	9.00	9.04	0	Runoff C	0.00	0.00	0.00	0.00	0.00	0.00
C	0.83	0.84	0.85	0.86	0.87	0.87		Q (m ³ /s)	0.000	0.000	0.000	0.000	0.000	0.000
i (mm/hr)	166	209	237	273	293	322		i (mm/hr)	78	102	118	138	153	168
Runoff C	0.00	0.00	0.00	0.00	0.00	0.00	202	Runoff C	0.74	0.74	0.74	0.81	0.89	0.93
Q (m ³ /s)	0.000	0.000	0.000	0.000	0.000	0.000		Q (m ³ /s)	0.004	0.005	0.006	0.008	0.009	0.011

Rational Method Calculation

Project Details

Victoria Annex	120174
----------------	--------

Prepared By

MJF	October 1, 2021
-----	-----------------

Municipality

Town of Collingwood

Pre-Development Analysis

Catchment ID:	
Catchment Area (ha):	
Runoff Coefficient:	
Time of Concentration (min):	

Post-Development Analysis

Catchment ID:	203
Catchment Area (ha):	0.08
Runoff Coefficient:	0.84
Time of Concentration (min):	10.00

Design Storm	Pre-Development						Design Storm	Post-Development						
	2YR	5YR	10YR	25YR	50YR	100YR		Controlled	Uncontrolled					
A	807	1135	1387	1676	1973	2193	i (mm/hr)	166	209	237	273	293	322	
B	6.75	7.50	7.97	8.30	9.00	9.04	0	Runoff C	0.00	0.00	0.00	0.00	0.00	0.00
C	0.83	0.84	0.85	0.86	0.87	0.87		Q (m ³ /s)	0.000	0.000	0.000	0.000	0.000	0.000
i (mm/hr)	166	209	237	273	293	322		i (mm/hr)	78	102	118	138	153	168
Runoff C	0.00	0.00	0.00	0.00	0.00	0.00	203	Runoff C	0.84	0.84	0.84	0.93	1.00	1.00
Q (m ³ /s)	0.000	0.000	0.000	0.000	0.000	0.000		Q (m ³ /s)	0.015	0.020	0.023	0.029	0.035	0.038

Rational Method Calculation

Project Details

Victoria Annex	120174
----------------	--------

Prepared By

MJF	October 1, 2021
-----	-----------------

Municipality

Town of Collingwood

Pre-Development Analysis

Catchment ID:	
Catchment Area (ha):	
Runoff Coefficient:	
Time of Concentration (min):	

Post-Development Analysis

Catchment ID:	204
Catchment Area (ha):	0.04
Runoff Coefficient:	0.47
Time of Concentration (min):	10.00

Design Storm	Pre-Development						Design Storm	Post-Development						
	2YR	5YR	10YR	25YR	50YR	100YR		2YR	5YR	10YR	25YR	50YR	100YR	
A	807	1135	1387	1676	1973	2193	i (mm/hr)	166	209	237	273	293	322	
B	6.75	7.50	7.97	8.30	9.00	9.04	0	Runoff C	0.00	0.00	0.00	0.00	0.00	0.00
C	0.83	0.84	0.85	0.86	0.87	0.87	Q (m ³ /s)	0.000	0.000	0.000	0.000	0.000	0.000	
i (mm/hr)	166	209	237	273	293	322	i (mm/hr)	78	102	118	138	153	168	
Runoff C	0.00	0.00	0.00	0.00	0.00	0.00	204	Runoff C	0.47	0.47	0.47	0.51	0.56	0.58
Q (m ³ /s)	0.000	0.000	0.000	0.000	0.000	0.000	Q (m ³ /s)	0.004	0.006	0.007	0.009	0.010	0.012	

Rational Method Calculation

Project Details

Victoria Annex	120174
----------------	--------

Prepared By

MJF	October 1, 2021
-----	-----------------

Municipality

Town of Collingwood

Pre-Development Analysis

Catchment ID:	
Catchment Area (ha):	
Runoff Coefficient:	
Time of Concentration (min):	

Post-Development Analysis

Catchment ID:	205
Catchment Area (ha):	0.04
Runoff Coefficient:	0.53
Time of Concentration (min):	10.00

Design Storm	Pre-Development						Design Storm	Post-Development						
	2YR	5YR	10YR	25YR	50YR	100YR		Controlled	Uncontrolled					
A	807	1135	1387	1676	1973	2193	i (mm/hr)	166	209	237	273	293	322	
B	6.75	7.50	7.97	8.30	9.00	9.04	0	Runoff C	0.00	0.00	0.00	0.00	0.00	0.00
C	0.83	0.84	0.85	0.86	0.87	0.87		Q (m ³ /s)	0.000	0.000	0.000	0.000	0.000	0.000
i (mm/hr)	166	209	237	273	293	322		i (mm/hr)	78	102	118	138	153	168
Runoff C	0.00	0.00	0.00	0.00	0.00	0.00	205	Runoff C	0.53	0.53	0.53	0.58	0.63	0.66
Q (m ³ /s)	0.000	0.000	0.000	0.000	0.000	0.000		Q (m ³ /s)	0.005	0.006	0.007	0.009	0.011	0.013

Rational Method Calculation

Project Details

Victoria Annex	120174
----------------	--------

Prepared By

MJF	October 1, 2021
-----	-----------------

Municipality

Town of Collingwood

Pre-Development Analysis

Catchment ID:	
Catchment Area (ha):	
Runoff Coefficient:	
Time of Concentration (min):	

Post-Development Analysis

Catchment ID:	P1
Catchment Area (ha):	0.12
Runoff Coefficient:	0.66
Time of Concentration (min):	10.00

Design Storm	Pre-Development						Design Storm	Post-Development						
	2YR	5YR	10YR	25YR	50YR	100YR		2YR	5YR	10YR	25YR	50YR	100YR	
A	807	1135	1387	1676	1973	2193	i (mm/hr)	166	209	237	273	293	322	
B	6.75	7.50	7.97	8.30	9.00	9.04	0	Runoff C	0.00	0.00	0.00	0.00	0.00	0.00
C	0.83	0.84	0.85	0.86	0.87	0.87		Q (m ³ /s)	0.000	0.000	0.000	0.000	0.000	0.000
i (mm/hr)	166	209	237	273	293	322		i (mm/hr)	78	102	118	138	153	168
Runoff C	0.00	0.00	0.00	0.00	0.00	0.00	P1	Runoff C	0.66	0.66	0.66	0.73	0.79	0.82
Q (m ³ /s)	0.000	0.000	0.000	0.000	0.000	0.000		Q (m ³ /s)	0.017	0.022	0.025	0.032	0.039	0.045

Rational Method Calculation

Project Details

Victoria Annex	120174
----------------	--------

Prepared By

MJF	October 1, 2021
-----	-----------------

Municipality

Town of Collingwood

Pre-Development Analysis

Catchment ID:	
Catchment Area (ha):	
Runoff Coefficient:	
Time of Concentration (min):	

Post-Development Analysis

Catchment ID:	P2
Catchment Area (ha):	0.10
Runoff Coefficient:	0.64
Time of Concentration (min):	10.00

Design Storm	Pre-Development						Design Storm	Post-Development						
	2YR	5YR	10YR	25YR	50YR	100YR		2YR	5YR	10YR	25YR	50YR	100YR	
A	807	1135	1387	1676	1973	2193	i (mm/hr)	166	209	237	273	293	322	
B	6.75	7.50	7.97	8.30	9.00	9.04	0	Runoff C	0.00	0.00	0.00	0.00	0.00	0.00
C	0.83	0.84	0.85	0.86	0.87	0.87	Q (m ³ /s)	0.000	0.000	0.000	0.000	0.000	0.000	
i (mm/hr)	166	209	237	273	293	322	P2	i (mm/hr)	78	102	118	138	153	168
Runoff C	0.00	0.00	0.00	0.00	0.00	0.00	Runoff C	0.64	0.64	0.64	0.70	0.76	0.80	
Q (m ³ /s)	0.000	0.000	0.000	0.000	0.000	0.000	Q (m ³ /s)	0.013	0.017	0.020	0.026	0.031	0.036	

Rational Method Calculation

Project Details

Victoria Annex	120174
----------------	--------

Prepared By

MJF	October 1, 2021
-----	-----------------

Municipality

Town of Collingwood

Pre-Development Analysis

Catchment ID:	
Catchment Area (ha):	
Runoff Coefficient:	
Time of Concentration (min):	

Post-Development Analysis

Catchment ID:	P3
Catchment Area (ha):	0.28
Runoff Coefficient:	0.62
Time of Concentration (min):	10.00

Design Storm	Pre-Development						Design Storm	Post-Development						
	2YR	5YR	10YR	25YR	50YR	100YR		Controlled	Uncontrolled					
A	807	1135	1387	1676	1973	2193	i (mm/hr)	166	209	237	273	293	322	
B	6.75	7.50	7.97	8.30	9.00	9.04	0	Runoff C	0.00	0.00	0.00	0.00	0.00	0.00
C	0.83	0.84	0.85	0.86	0.87	0.87		Q (m ³ /s)	0.000	0.000	0.000	0.000	0.000	0.000
i (mm/hr)	166	209	237	273	293	322		i (mm/hr)	78	102	118	138	153	168
Runoff C	0.00	0.00	0.00	0.00	0.00	0.00	P3	Runoff C	0.62	0.62	0.62	0.68	0.74	0.78
Q (m ³ /s)	0.000	0.000	0.000	0.000	0.000	0.000		Q (m ³ /s)	0.038	0.049	0.057	0.073	0.088	0.101

Rational Method Calculation

Project Details

Victoria Annex	120174
----------------	--------

Prepared By

MJF	October 1, 2021
-----	-----------------

Municipality

Town of Collingwood

Pre-Development Analysis

Catchment ID:	
Catchment Area (ha):	
Runoff Coefficient:	
Time of Concentration (min):	

Post-Development Analysis

Catchment ID:	P4
Catchment Area (ha):	0.11
Runoff Coefficient:	0.62
Time of Concentration (min):	10.00

Design Storm	Pre-Development						Design Storm	Post-Development						
	2YR	5YR	10YR	25YR	50YR	100YR		2YR	5YR	10YR	25YR	50YR	100YR	
A	807	1135	1387	1676	1973	2193	i (mm/hr)	166	209	237	273	293	322	
B	6.75	7.50	7.97	8.30	9.00	9.04	0	Runoff C	0.00	0.00	0.00	0.00	0.00	0.00
C	0.83	0.84	0.85	0.86	0.87	0.87		Q (m ³ /s)	0.000	0.000	0.000	0.000	0.000	0.000
i (mm/hr)	166	209	237	273	293	322		i (mm/hr)	78	102	118	138	153	168
Runoff C	0.00	0.00	0.00	0.00	0.00	0.00	P4	Runoff C	0.62	0.62	0.62	0.68	0.75	0.78
Q (m ³ /s)	0.000	0.000	0.000	0.000	0.000	0.000		Q (m ³ /s)	0.015	0.019	0.022	0.029	0.035	0.040

**Appendix C:
Modified Rational Method for
Quantity Control Storage
Requirements**

Modified Rational Method Calculation

Project Details

Victoria Annex	120174
----------------	--------

Prepared By

MJF	September 16, 2021
-----	--------------------

Municipality

Town of Collingwood

Pre-Development Analysis

Catchment ID:	E3
Catchment Area (ha):	0.31
Runoff Coefficient:	0.44
Time of Concentration (min):	10.00

Post-Development Analysis

Controlled Uncontrolled

Catchment ID:	201-204	P4, 205
Catchment Area (ha):	0.18	0.15
Runoff Coefficient:	0.71	0.60
Time of Concentration (min):	10.00	10.00

Design Storm	2YR	5YR	10YR	25YR	50YR	100YR	Design Storm	2YR	5YR	10YR	25YR	50YR	100YR	
A	807	1135	1387	1676	1973	2193	201-204	i (mm/hr)	78	102	118	138	153	168
B	6.75	7.50	7.97	8.30	9.00	9.04		Runoff C	0.71	0.71	0.71	0.79	0.86	0.89
C	0.83	0.84	0.85	0.86	0.87	0.87		Q (m ³ /s)	0.027	0.036	0.042	0.053	0.064	0.074
i (mm/hr)	78	102	118	138	153	168	P4, 205	i (mm/hr)	78	102	118	138	153	168
Runoff C	0.44	0.44	0.44	0.48	0.53	0.55		Runoff C	0.60	0.60	0.60	0.65	0.71	0.74
Q (m ³ /s)	0.030	0.039	0.046	0.059	0.071	0.081		Q (m ³ /s)	0.020	0.026	0.030	0.038	0.046	0.053

Peak Runoff Rate (m³/s) - Rational Method (Q=CiA/360)

Storm	Q _{EXISTING}	Q _{NO CONTROLS}	Q _{UNCONTROLLED}	Q _{CONTROLLED}	Q _{TOTAL}	Q _{REDUCTION}	
2YR	0.030	0.047	0.020	0.010	0.030	0.037	m ³ /s
5YR	0.039	0.062	0.026	0.014	0.039	0.048	m ³ /s
10YR	0.046	0.071	0.030	0.016	0.046	0.055	m ³ /s
25YR	0.059	0.092	0.038	0.020	0.059	0.071	m ³ /s
50YR	0.071	0.111	0.046	0.025	0.071	0.086	m ³ /s
100YR	0.081	0.127	0.053	0.028	0.081	0.099	m ³ /s

Required Storage Volumes (m³) - Modified Rational Method (V_p = Q_p x D - Q_o x ((D + t_c)/2))

Dur. (min)	2YR	5YR	10YR	25YR	50YR	100YR
10	10	13	15	20	24	27
20	13	17	20	26	31	36
30	13	18	21	27	33	37
40	12	17	19	25	31	36
50	11	15	17	23	28	32
60	9	13	15	19	24	27
70	8	10	12	16	20	22

Appendix D: Orifice Discharge Calculations

	Project: Victoria Annex	Date: 2021-10-06
	File No.: 120174	Designed: MJF
	Subject: Oriface Discharge Calculations	Checked: KRS

OGS1 North Inlet Orifice

Orifice Dia. (mm)	75
Cross Sectional Area (m²)	0.0044
Orifice Coefficient	0.80 Short tube orifice
Orifice Invert Elevation (m)	184.07

Water Elevation (m)	Head (m)	Discharge (cms)
184.04	0.00	0.000
184.14	0.03	0.003
184.24	0.13	0.006
184.34	0.23	0.008
184.44	0.33	0.009
184.54	0.43	0.010
184.64	0.53	0.011
184.74	0.63	0.012
184.84	0.73	0.013
184.94	0.83	0.014
185.04	0.93	0.015
185.14	1.03	0.016
185.24	1.13	0.017

CBMH405 West Inlet Orifice

Orifice Dia. (mm)	75
Cross Sectional Area (m²)	0.0044
Orifice Coefficient	0.80 Short tube orifice
Orifice Invert Elevation (m)	184.01

Water Elevation (m)	Head (m)	Discharge (cms)
184.04	0.00	0.000
184.14	0.09	0.005
184.24	0.19	0.007
184.34	0.29	0.008
184.44	0.39	0.010
184.54	0.49	0.011
184.64	0.59	0.012
184.74	0.69	0.013
184.84	0.79	0.014
184.94	0.89	0.015
185.04	0.99	0.016
185.14	1.09	0.016
185.24	1.19	0.017

Appendix E: Stormceptor Sizing



Stormceptor® **EF** Sizing Report

STORMCEPTOR®

ESTIMATED NET ANNUAL SEDIMENT (TSS) LOAD REDUCTION

11/16/2020

Province:	Ontario
City:	Collingwood
Nearest Rainfall Station:	OWEN SOUND MOE
NCDC Rainfall Station Id:	6132
Years of Rainfall Data:	40

Project Name:	Victoria Annex
Project Number:	120174
Designer Name:	Mark Figueroa
Designer Company:	Tatham Engineering Limited
Designer Email:	mfigueroa@tathameng.com
Designer Phone:	705-888-6509
EOR Name:	
EOR Company:	
EOR Email:	
EOR Phone:	

Site Name:	Victoria Annex
Drainage Area (ha):	0.22
Runoff Coefficient 'c':	0.64
Particle Size Distribution:	Fine
Target TSS Removal (%):	80.0

Required Water Quality Runoff Volume Capture (%):	
Estimated Water Quality Flow Rate (L/s):	
Oil / Fuel Spill Risk Site?	Yes
Upstream Flow Control?	No
Peak Conveyance (maximum) Flow Rate (L/s):	
Site Sediment Transport Rate (kg/ha/yr):	

Net Annual Sediment (TSS) Load Reduction Sizing Summary	
Stormceptor Model	TSS Removal Provided (%)
EFO4	87
EFO6	91
EFO8	92
EFO10	93
EFO12	93

Recommended Stormceptor EFO Model: EFO4
Estimated Net Annual Sediment (TSS) Load Reduction (%): 87



Stormceptor® EF Sizing Report

THIRD-PARTY TESTING AND VERIFICATION

► **Stormceptor® EF and Stormceptor® EFO** are the latest evolutions in the Stormceptor® oil-grit separator (OGS) technology series, and are designed to remove a wide variety of pollutants from stormwater and snowmelt runoff. These technologies have been third-party tested in accordance with the Canadian ETV **Procedure for Laboratory Testing of Oil-Grit Separators** and performance has been third-party verified in accordance with the **ISO 14034 Environmental Technology Verification (ETV)** protocol.

PERFORMANCE

► **Stormceptor® EF and EFO** remove stormwater pollutants through gravity separation and floatation, and feature a patent-pending design that generates positive removal of total suspended solids (TSS) throughout each storm event, including high-intensity storms. Captured pollutants include sediment, free oils, and sediment-bound pollutants such as nutrients, heavy metals, and petroleum hydrocarbons. Stormceptor is sized to remove a high level of TSS from the frequent rainfall events that contribute the vast majority of annual runoff volume and pollutant load. The technology incorporates an internal bypass to convey excessive stormwater flows from high-intensity storms through the device without resuspension and washout (scour) of previously captured pollutants. Proper routine maintenance ensures high pollutant removal performance and protection of downstream waterways.

PARTICLE SIZE DISTRIBUTION (PSD)

► The **Canadian ETV PSD** shown in the table below was used, or in part, for this sizing. This is the identical PSD that is referenced in the Canadian ETV **Procedure for Laboratory Testing of Oil-Grit Separators** for both sediment removal testing and scour testing. The Canadian ETV PSD contains a wide range of particle sizes in the sand and silt fractions, and is considered reasonably representative of the particle size fractions found in typical urban stormwater runoff.

Particle Size (µm)	Percent Less Than	Particle Size Fraction (µm)	Percent
1000	100	500-1000	5
500	95	250-500	5
250	90	150-250	15
150	75	100-150	15
100	60	75-100	10
75	50	50-75	5
50	45	20-50	10
20	35	8-20	15
8	20	5-8	10
5	10	2-5	5
2	5	<2	5

Stormceptor®**EF** Sizing Report

Rainfall Intensity (mm / hr)	Percent Rainfall Volume (%)	Cumulative Rainfall Volume (%)	Flow Rate (L/s)	Flow Rate (L/min)	Surface Loading Rate (L/min/m ²)	Removal Efficiency (%)	Incremental Removal (%)	Cumulative Removal (%)
1	50.7	50.7	0.39	23.0	20.0	93	47.2	47.2
2	9.4	60.1	0.78	47.0	39.0	93	8.7	55.9
3	6.8	66.9	1.17	70.0	59.0	92	6.3	62.1
4	5.0	71.9	1.57	94.0	78.0	90	4.5	66.6
5	4.1	76.0	1.96	117.0	98.0	88	3.6	70.3
6	3.1	79.1	2.35	141.0	117.0	86	2.7	72.9
7	2.3	81.4	2.74	164.0	137.0	84	1.9	74.8
8	2.5	83.9	3.13	188.0	157.0	81	2.0	76.9
9	1.8	85.7	3.52	211.0	176.0	79	1.4	78.3
10	1.5	87.2	3.91	235.0	196.0	77	1.2	79.5
11	1.2	88.4	4.31	258.0	215.0	75	0.9	80.4
12	1.1	89.5	4.70	282.0	235.0	73	0.8	81.2
13	1.3	90.8	5.09	305.0	254.0	72	0.9	82.1
14	0.7	91.5	5.48	329.0	274.0	70	0.5	82.6
15	0.7	92.2	5.87	352.0	294.0	68	0.5	83.1
16	0.6	92.8	6.26	376.0	313.0	66	0.4	83.4
17	0.9	93.7	6.65	399.0	333.0	64	0.6	84.0
18	0.6	94.3	7.05	423.0	352.0	63	0.4	84.4
19	0.5	94.8	7.44	446.0	372.0	61	0.3	84.7
20	0.5	95.3	7.83	470.0	391.0	59	0.3	85.0
21	0.4	95.7	8.22	493.0	411.0	58	0.2	85.2
22	0.5	96.2	8.61	517.0	431.0	57	0.3	85.5
23	0.3	96.5	9.00	540.0	450.0	57	0.2	85.7
24	0.2	96.7	9.39	564.0	470.0	56	0.1	85.8
25	0.4	97.1	9.79	587.0	489.0	55	0.2	86.0

Stormceptor® **EF** Sizing Report

Rainfall Intensity (mm / hr)	Percent Rainfall Volume (%)	Cumulative Rainfall Volume (%)	Flow Rate (L/s)	Flow Rate (L/min)	Surface Loading Rate (L/min/m ²)	Removal Efficiency (%)	Incremental Removal (%)	Cumulative Removal (%)
26	0.3	97.4	10.18	611.0	509.0	55	0.2	86.2
27	0.3	97.7	10.57	634.0	528.0	54	0.2	86.3
28	0.2	97.9	10.96	658.0	548.0	54	0.1	86.5
29	0.1	98.0	11.35	681.0	568.0	53	0.1	86.5
30	0.2	98.2	11.74	705.0	587.0	53	0.1	86.6
31	0.2	98.4	12.13	728.0	607.0	52	0.1	86.7
32	0.2	98.6	12.53	752.0	626.0	52	0.1	86.8
33	0.1	98.7	12.92	775.0	646.0	52	0.1	86.9
34	0.1	98.8	13.31	799.0	665.0	52	0.1	86.9
35	0.1	98.9	13.70	822.0	685.0	52	0.1	87.0
36	0.1	99.0	14.09	845.0	705.0	52	0.1	87.0
37	0.1	99.1	14.48	869.0	724.0	51	0.1	87.1
38	0.1	99.2	14.87	892.0	744.0	51	0.1	87.1
39	0.0	99.2	15.27	916.0	763.0	51	0.0	87.1
40	0.0	99.2	15.66	939.0	783.0	51	0.0	87.1
41	0.1	99.3	16.05	963.0	802.0	51	0.1	87.2
42	0.1	99.4	16.44	986.0	822.0	51	0.1	87.2
43	0.1	99.5	16.83	1010.0	842.0	51	0.1	87.3
44	0.0	99.5	17.22	1033.0	861.0	51	0.0	87.3
45	0.1	99.6	17.61	1057.0	881.0	51	0.1	87.3
46	0.1	99.7	18.01	1080.0	900.0	51	0.1	87.4
47	0.1	99.8	18.40	1104.0	920.0	50	0.1	87.4
48	0.0	99.8	18.79	1127.0	939.0	50	0.0	87.4
49	0.0	99.8	19.18	1151.0	959.0	50	0.0	87.4
50	0.0	99.8	19.57	1174.0	979.0	50	0.0	87.4
Estimated Net Annual Sediment (TSS) Load Reduction =								87 %

Stormceptor® EF Sizing Report

RAINFALL DATA FROM OWEN SOUND MOE RAINFALL STATION

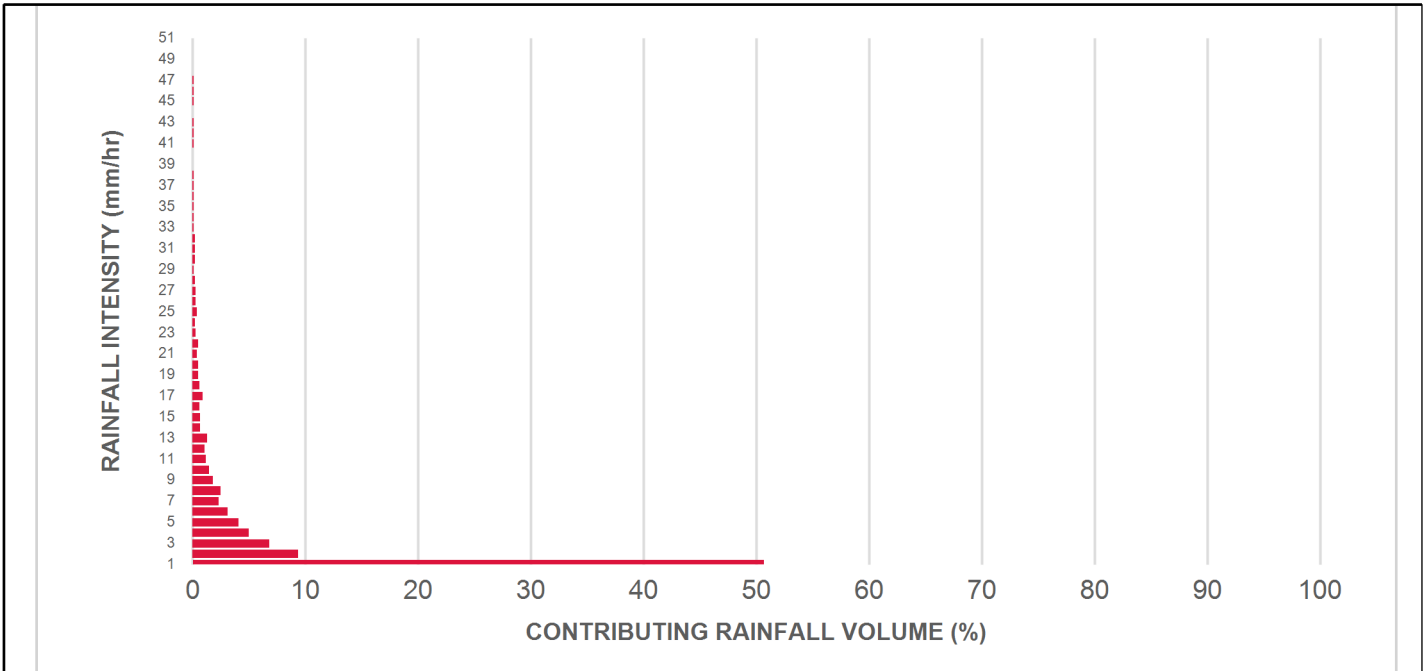

INCREMENTAL AND CUMULATIVE TSS REMOVAL FOR THE RECOMMENDED STORMCEPTOR® MODEL

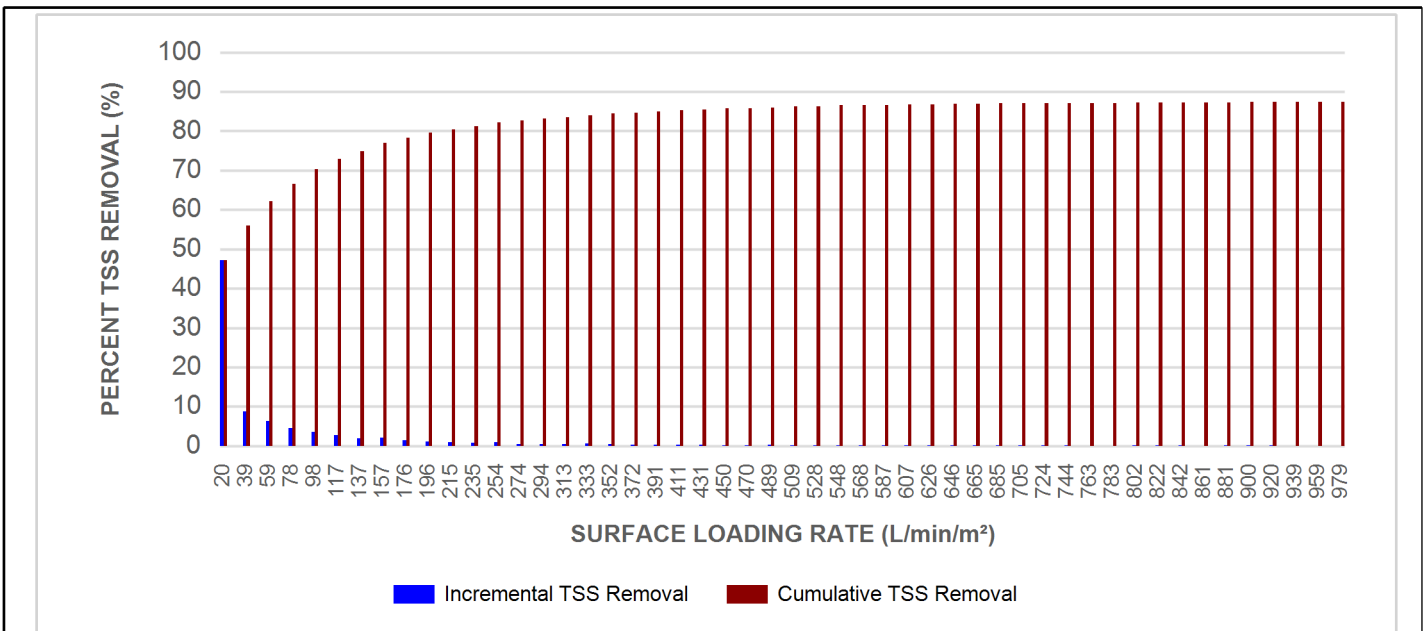

Stormceptor® EF Sizing Report

Maximum Pipe Diameter / Peak Conveyance

Stormceptor EF / EFO	Model Diameter		Min Angle Inlet / Outlet Pipes	Max Inlet Pipe Diameter		Max Outlet Pipe Diameter		Peak Conveyance Flow Rate	
	(m)	(ft)		(mm)	(in)	(mm)	(in)	(L/s)	(cfs)
EF4 / EFO4	1.2	4	90	609	24	609	24	425	15
EF6 / EFO6	1.8	6	90	914	36	914	36	990	35
EF8 / EFO8	2.4	8	90	1219	48	1219	48	1700	60
EF10 / EFO10	3.0	10	90	1828	72	1828	72	2830	100
EF12 / EFO12	3.6	12	90	1828	72	1828	72	2830	100

SCOUR PREVENTION AND ONLINE CONFIGURATION

► Stormceptor® EF and EFO feature an internal bypass and superior scour prevention technology that have been demonstrated in third-party testing according to the scour testing provisions of the Canadian ETV **Procedure for Laboratory Testing of Oil-Grit Separators**, and the exceptional scour test performance has been third-party verified in accordance with the ISO 14034 ETV protocol. As a result, Stormceptor EF and EFO are approved for online installation, eliminating the need for costly additional bypass structures, piping, and installation expense.

DESIGN FLEXIBILITY

► Stormceptor® EF and EFO offers design flexibility in one simplified platform, accepting stormwater flow from a single inlet pipe or multiple inlet pipes, and/or surface runoff through an inlet grate. The device can also serve as a junction structure, accommodate a 90-degree inlet-to-outlet bend angle, and can be modified to ensure performance in submerged conditions.

OIL CAPTURE AND RETENTION

► While Stormceptor® EF will capture and retain oil from dry weather spills and low intensity runoff, Stormceptor® EFO has demonstrated superior oil capture and greater than 99% oil retention in third-party testing according to the light liquid re-entrainment testing provisions of the Canadian ETV **Procedure for Laboratory Testing of Oil-Grit Separators**. Stormceptor EFO is recommended for sites where oil capture and retention is a requirement.

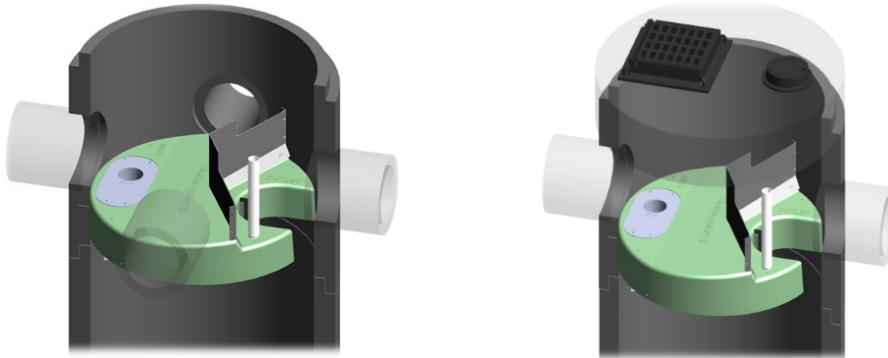

Stormceptor® EF Sizing Report

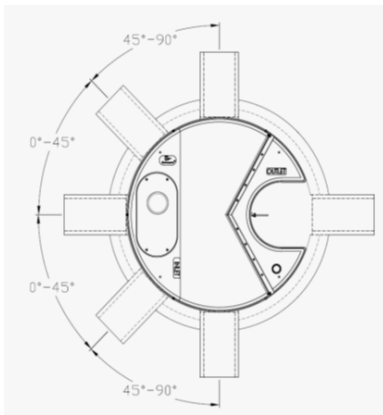

INLET-TO-OUTLET DROP

Elevation differential between inlet and outlet pipe inverts is dictated by the angle at which the inlet pipe(s) enters the unit.

0° - 45° : The inlet pipe is 1-inch (25mm) higher than the outlet pipe.

45° - 90° : The inlet pipe is 2-inches (50mm) higher than the outlet pipe.

HEAD LOSS

The head loss through Stormceptor EF is similar to that of a 60-degree bend structure. The applicable K value for calculating minor losses through the unit is 1.1.

For submerged conditions the applicable K value is 3.0.

Pollutant Capacity

Stormceptor EF / EFO	Model Diameter		Depth (Outlet Pipe Invert to Sump Floor)		Oil Volume		Recommended Sediment Maintenance Depth *		Maximum Sediment Volume *		Maximum Sediment Mass **	
	(m)	(ft)	(m)	(ft)	(L)	(Gal)	(mm)	(in)	(L)	(ft³)	(kg)	(lb)
EF4 / EFO4	1.2	4	1.52	5.0	265	70	203	8	1190	42	1904	5250
EF6 / EFO6	1.8	6	1.93	6.3	610	160	305	12	3470	123	5552	15375
EF8 / EFO8	2.4	8	2.59	8.5	1070	280	610	24	8780	310	14048	38750
EF10 / EFO10	3.0	10	3.25	10.7	1670	440	610	24	17790	628	28464	78500
EF12 / EFO12	3.6	12	3.89	12.8	2475	655	610	24	31220	1103	49952	137875

*Increased sump depth may be added to increase sediment storage capacity

** Average density of wet packed sediment in sump = 1.6 kg/L (100 lb/ft³)

Feature	Benefit	Feature Appeals To
Patent-pending enhanced flow treatment and scour prevention technology	Superior, verified third-party performance	Regulator, Specifying & Design Engineer
Third-party verified light liquid capture and retention for EFO version	Proven performance for fuel/oil hotspot locations	Regulator, Specifying & Design Engineer, Site Owner
Functions as bend, junction or inlet structure	Design flexibility	Specifying & Design Engineer
Minimal drop between inlet and outlet	Site installation ease	Contractor
Large diameter outlet riser for inspection and maintenance	Easy maintenance access from grade	Maintenance Contractor & Site Owner

STANDARD STORMCEPTOR EF/EFO DRAWINGS

For standard details, please visit <http://www.imbrium.com/stormwater-treatment-solutions/stormceptor-ef>

STANDARD STORMCEPTOR EF/EFO SPECIFICATION

For specifications, please visit <http://www.imbrium.com/stormwater-treatment-solutions/stormceptor-ef>

**STANDARD PERFORMANCE SPECIFICATION FOR
“OIL GRIT SEPARATOR” (OGS) STORMWATER QUALITY TREATMENT DEVICE**

PART 1 – GENERAL

1.1 WORK INCLUDED

This section specifies requirements for selecting, sizing, and designing an underground Oil Grit Separator (OGS) device for stormwater quality treatment, with third-party testing results and a Statement of Verification in accordance with ISO 14034 Environmental Management – Environmental Technology Verification (ETV).

1.2 REFERENCE STANDARDS & PROCEDURES

ISO 14034:2016 Environmental management – Environmental technology verification (ETV)

Canadian Environmental Technology Verification (ETV) Program’s **Procedure for Laboratory Testing of Oil-Grit Separators**

1.3 SUBMITTALS

1.3.1 All submittals, including sizing reports & shop drawings, shall be submitted upon request with each order to the contractor then forwarded to the Engineer of Record for review and acceptance. Shop drawings shall detail all OGS components, elevations, and sequence of construction.

1.3.2 Alternative devices shall have features identical to or greater than the specified device, including: treatment chamber diameter, treatment chamber wet volume, sediment storage volume, and oil storage volume.

1.3.3 Unless directed otherwise by the Engineer of Record, OGS stormwater quality treatment product substitutions or alternatives submitted within ten days prior to project bid shall not be accepted. All alternatives or substitutions submitted shall be signed and sealed by a local registered Professional Engineer, based on the exact same criteria detailed in Section 3, in entirety, subject to review and approval by the Engineer of Record.

PART 2 – PRODUCTS

2.1 OGS POLLUTANT STORAGE

The OGS device shall include a sump for sediment storage, and a protected volume for the capture and storage of petroleum hydrocarbons and buoyant gross pollutants. The minimum sediment & petroleum hydrocarbon storage capacity shall be as follows:

2.1.1	4 ft (1219 mm) Diameter OGS Units:	1.19 m ³ sediment / 265 L oil
	6 ft (1829 mm) Diameter OGS Units:	3.48 m ³ sediment / 609 L oil
	8 ft (2438 mm) Diameter OGS Units:	8.78 m ³ sediment / 1,071 L oil
	10 ft (3048 mm) Diameter OGS Units:	17.78 m ³ sediment / 1,673 L oil
	12 ft (3657 mm) Diameter OGS Units:	31.23 m ³ sediment / 2,476 L oil

PART 3 – PERFORMANCE & DESIGN

3.1 GENERAL

The OGS stormwater quality treatment device shall be verified in accordance with ISO 14034:2016 Environmental management – Environmental technology verification (ETV). The OGS stormwater quality treatment device shall



Stormceptor®EF Sizing Report

remove oil, sediment and gross pollutants from stormwater runoff during frequent wet weather events, and retain these pollutants during less frequent high flow wet weather events below the insert within the OGS for later removal during maintenance. The Manufacturer shall have at least ten (10) years of local experience, history and success in engineering design, manufacturing and production and supply of OGS stormwater quality treatment device systems, acceptable to the Engineer of Record.

3.2 SIZING METHODOLOGY

The OGS device shall be engineered, designed and sized to provide stormwater quality treatment based on treating a minimum of 90 percent of the average annual runoff volume and a minimum removal of an annual average 60% of the sediment (TSS) load based on the Particle Size Distribution (PSD) specified in the sizing report for the specified device. Sizing shall be determined using historical rainfall data and a sediment removal performance curve derived from the actual third-party verified laboratory testing data. The OGS device shall also have sufficient annual sediment storage capacity as specified and calculated in Section 2.1.

3.3 CANADIAN ETV or ISO 14034 ETV VERIFICATION OF SCOUR TESTING

The OGS device shall have Canadian ETV or ISO 14034 ETV Verification of third-party scour testing conducted in accordance with the Canadian ETV Program's **Procedure for Laboratory Testing of Oil-Grit Separators**.

3.3.1 To be acceptable for on-line installation, the OGS device must demonstrate an average scour test effluent concentration less than 10 mg/L at each surface loading rate tested, up to and including 2600 L/min/m².

3.4 LIGHT LIQUID RE-ENTRAINMENT SIMULATION TESTING

The OGS device shall have Canadian ETV or ISO 14034 ETV Verification of completed third-party Light Liquid Re-entrainment Simulation Testing in accordance with the Canadian ETV **Program's Procedure for Laboratory Testing of Oil-Grit Separators**, with results reported within the Canadian ETV or ISO 14034 ETV verification. This re-entrainment testing is conducted with the device pre-loaded with low density polyethylene (LDPE) plastic beads as a surrogate for light liquids such as oil and fuel. Testing is conducted on the same OGS unit tested for sediment removal to assess whether light liquids captured after a spill are effectively retained at high flow rates.

3.4.1 For an OGS device to be an acceptable stormwater treatment device on a site where vehicular traffic occurs and the potential for an oil or fuel spill exists, the OGS device must have reported verified performance results of greater than 99% cumulative retention of LDPE plastic beads for the five specified surface loading rates (ranging 200 L/min/m² to 2600 L/min/m²) in accordance with the Light Liquid Re-entrainment Simulation Testing within the Canadian ETV Program's **Procedure for Laboratory Testing of Oil-Grit Separators**. However, an OGS device shall not be allowed if the Light Liquid Re-entrainment Simulation Testing was performed with screening components within the OGS device that are effective at retaining the LDPE plastic beads, but would not be expected to retain light liquids such as oil and fuel.